

Operating Instructions



Manufacturer:
DKL CHAIRS GmbH
An der Ziegelei 3
D-37124 Rosdorf
Germany
+49 (0)551-50060
info@dkl.de
www.dkl.de



L2-SOLO



L2-SOLO-S

Form-Nr. GEN-L2SOLO
Rev. 05 / 26.05.2023
Subject to change without
notice.







Contents

Symbols in the Operating Instructions	3
Symbols inside the Unit	4
Introduction	5
Electromagnetic Compatibility (EMC)	6
Safety Notes – General	7
Technical Specifications	8
Media Requirements	9
Dimensions in Millimetres	11
Product Description	13
Working Properly on the L2	14
Moving the Treatment Chair	15
Putting the Treatment Unit into Operation	17
Operating Lamp LED.light EVA	18
Tray	21
Cuspidor	22
Suction System	23
Cleaning and Disinfection of the Surfaces	24
Maintenance and Inspection	27
Safety Inspections	27
Warranty Declaration + Waste Disposal	28
EMC - Manufacturer's Declaration	29













Annex

- > Operating Instructions DÜRR Dental Spittoon valve 3
- > Operating Instructions DÜRR Dental CAS 1 Combi-Separator
- > Operating Instructions DÜRR Dental CS 1 Combi-Sepamatic
- > USER MANUAL FARO EVA

Symbols in the Operating Instructions

	WARNING! (risk of injury)		CAUTION! (to prevent damage occurring)		General explanations, without risk to persons or objects
	Thermodisinfectable		Sterilisable up to the specified temperature		Call customer service!

Symbols on the unit

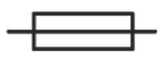
	Consult instructions for use or consult electronic instructions for use		ON / OFF		Do not dispose of with household waste
	CE-marking with identification number of the notified body		Foot controller		Type B application part
	Manufacturing date		Model (designation)		Serial number
	Manufacturer		Medical device		UDI - Product Identification
V	Electrical voltage	AC	Alternating current	VA	Electrical power consumption
A	Current intensity	Hz	Frequency of alternating current		
	Electrical fuse				

Symbols inside the Unit



Earth conductor connection -
Protective earth



Functional
earth

N

Connection point for
neutral conductor

Symbols on the packaging

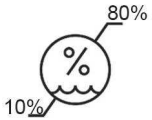

Air humidity, limitation

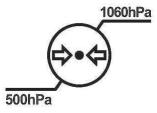

Atmospheric pressure limitation

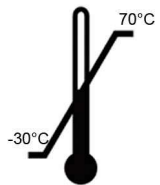

Permissible temperature range



Transport upright; top



Protect from moisture!

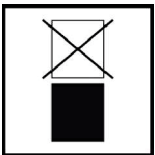

Do not stack!



Fragile

Introduction



For your safety and the safety of your patients

These operating instructions are intended to explain how to use your product. However, we must also warn of possible dangerous situations. Your safety, the safety of your team and, of course, the safety of your patients are very important to us.

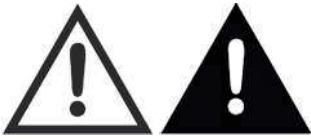

Please observe the safety instructions!

Intended purpose

This treatment unit is used for the diagnosis and therapy of children and adults in the field of dentistry.



Improper use can damage the treatment unit and thus pose risks and hazards to the patient, user and third parties.

Qualification of the user

The DKL treatment unit may only be used after medically, professionally and practically trained personnel have been instructed. The development and design of the treatment unit were geared towards the target group of dentists, dental hygienists, qualified dental employees (prophylaxis) and dental assistants.



Production according to EU directive

The medical device complies with the provisions of regulation (EU) 2017/745.



Responsibility of the manufacturer

The manufacturer can only be held responsible for the impact on the safety, reliability and performance of the treatment unit if the following instructions are observed:

- > The dental unit must be used in accordance with these operating instructions.
- > If assembly, additions, new settings, changes or repair work is carried out by DKL or trained technicians authorised by DKL or personnel of authorized dealers trained by DKL.
- > The electrical installation of the room must comply with the regulations of the IEC 60364-7-710 standard („Erection of electrical installations in rooms used for medical purposes“) or comply with the regulations applicable in your country.
- > The recommended annual maintenance is carried out and any repair work in this context meets the requirements of EN 62353.
- > „Repeat tests and pre-commissioning tests of medical electrical equipment and systems – general regulations“ are fully complied with.
- > The national legal regulations are observed when using the device, in particular the applicable health and safety regulations and accident prevention measures.

Electromagnetic Compatibility (EMC)



Medical electrical equipment is subject to special precautions with regard to EMC and must be installed and commissioned in accordance with the EMC instructions. DKL guarantees that the dental unit complies with the EMC guidelines only if original DKL accessories and spare parts are used. The use of accessories and spare parts not approved by DKL may lead to an increased emission of electromagnetic interference or to a reduced resistance to electromagnetic interference.



The EMC manufacturer declaration can be found on page 29.



HF communication equipment

Do not use portable and mobile HF-communication equipment (such as mobile telephones) during operation. These can affect medical electrical devices.



Risks due to electromagnetic fields

The functionality of implantable systems, such as cardiac pacemakers and implantable cardioverter defibrillators (ICD), can be influenced by electric, magnetic and electromagnetic fields.

- > Before using the product, ask the patient and user about implanted systems and check the use.
- > Perform a risk-benefit analysis.
- > Do not place the product near implanted systems.
- > Do not place the instruments on the patient's body.
- > Take appropriate emergency precautions and respond immediately to health changes.
- > Symptoms such as increased heart rate, irregular pulse, and dizziness may be signs of problems with a pacemaker or ICD.

Safety notes – General



- > Before being put into initial operation, the treatment unit must be kept at room temperature for 24 hours.
 - > Before each application, check the treatment unit and the instruments with cables for damage and loose parts.
- 
- > Do not operate the treatment unit if it is damaged.
 - > Check the set parameters each time you restart the unit.
 - > Carry out a test run before each application.
 - > The application and timely shutdown of the system is the user's responsibility.
 - > Make sure that in the event of a device or instrument failure, the treatment can be completed safely.
 - > Use only original DKL fuses.
 - > Never touch the patient and the electrical connection at the treatment unit at the same time.
 - > Do not lean on the tray or the operating lamp.
 - > When moving the treatment chair, the doctor's device, the assistant's device, the tray or the operating lamp, pay attention to the patient and the practice personnel.
 - > Always switch off the treatment unit before leaving the practice.



Hygiene and care before using the device

- > Clean and disinfect the device immediately before or after each treatment!
- > Wear protective clothing.



Observe your country-specific guidelines, standards and specifications for cleaning, disinfection and sterilisation.



The treatment unit is classified as an „ordinary device“ (closed device without protection against water ingress).



The treatment unit is not suitable for use in an explosive atmosphere or in explosive mixtures of anaesthetics with oxygen or nitrous oxide.



The treatment unit is not suitable for use in rooms with an oxygen enriched atmosphere.

Safety notes – Patient chair



- > Not suitable for patients who cannot remain in a resting position due to mental or physical disabilities.
- > The patient's arms and legs must rest on the upholstered parts of the chair.
- > Do not exceed the maximum patient weight of 150 kg.
- > Do not sit on the head or foot rest of the horizontally aligned patient chair.
- > Position changes must always be carried out under the surveillance of the person giving treatment.
- > Watch patients while moving the treatment chair.
- > Make sure that there are no objects under the treatment chair.

Technical Specifications



The motors of the treatment unit are designed for intermittent operation in accordance with the dental treatment method.

Driving motors for patient chair and backrest: duty cycle (max. 25 s „ON“ / 400 s „OFF“).

Supply voltage	230V AC
Nominal voltage	max. 4 A
Frequency	50/60 Hz
Fuse	T 6.3 A H 250 V primary
Maximum power consumption	800 VA
Device class according to MDR (EU) 2017/745	Ila
Protection class	Device of protection class I
Contamination level	2
Over voltage category	II
Power cable	3x1,5 mm ²
Suction control lines to the suction device	5x1,5 mm ²
Potential equalisation	1x 4 mm ²
Relay control line optional special function	3x1,5 mm ²
Free end electrical cables above floor	500 mm
Fuse for domestic installation	Circuit breaker: 16 A medium-lag Recommendation: circuit breaker type C
Degree of protection against ingress of water	Ordinary device (without protection against water ingress).



Permanently connected device. In order to avoid the risk of electric shock, this device may only be connected to a power supply with an earth conductor.

Weight	
L2-SOLO	max. 165 kg
L2-SOLO-S	max. 200 kg

Transport and storage conditions	
Ambient temperature	-30 to +70 °C
Relative humidity	10 to 80 %
Atmospheric pressure	500 hPa to 1060 hPa

Operating conditions	
Quality and load-bearing capacity of the floor	The floor must be level and horizontal according to EN 18202. Unevenness of the floor along the total length of the chair base up to 2 mm is acceptable. The minimum load-bearing capacity of the floor must be 0.5 N/cm ² (equivalent to approx. 500 kg/m ²).
Ambient temperature	10 to 35 °C
Relative humidity	15 to 80 %
Atmospheric pressure	700 hPa to 1060 hPa
Installation site	≤ 3,000 m above sea level The treatment unit is not suitable for operation in hazardous areas.

Media Requirements

Media water	
Water hardness	1.5 to 2.14 mmol/l = 8,4-12 dH
ph-value	6,5 to 8,5
Water filtration on site	≤ 100 µm
Water inflow	Pipe 10x1mm, angle valve outlet 3/8"
Water connection above floor	min. 40 mm, max. 60 mm
Water inlet pressure	2.0 to max. 6.0 bars
Water quality	Cold water in accordance with local and national drinking water regulations.
Minimum flow rate	3 l/min

- Perform the installation according to the national installation requirements (e.g. EN 1717).
- For the reduction of microorganisms in the water supply pipe, please observe the following when laying this pipe to the treatment unit:
 - Avoid long stub lines to the treatment unit.
 - Select the installation in such a way that other essential consumers (e.g. washbasin) are as far as possible behind the connection of the treatment unit can be supplied from the same pipe.
 - Avoid laying the hot water supply pipes in parallel.
- Recommendation: For the water supply of the treatment unit, install an angle valve with 2 outlets and 2 stop cocks. The second outlet allows easy sampling of water for microbiological analysis.

Connection to the public drinking water supply

When the treatment unit is equipped with a cuspidor, the bowl rinser ensures the free outlet with a separation distance ≥ 20 mm.



Before the treatment unit is installed, the microbiologically perfect water quality of the domestic water supply should be ensured and documented in the form of a microbial count. Sampling and microbial count should be carried out by a competent laboratory.

Media air	
Air inlet pressure	max. 7 bars
Air consumption	80 NI/min
On-site air filtration	≤ 100 particles size 1 - 5 µm referred to one m ³ of air
Oil content	≤ 0.5mg/m ³ , oil-free compressors; the compressor must suck in hygienically perfect air.
Humidity	Pressure dew point ≤ -20 °C at atmospheric pressure
Compressed air supply	Pipe 10x1 mm, angle valve outlet 3/8"
Air connection above the floor	min. 40 mm, max. 60 mm



Clean air and water pipes before installing the unit.

Chips and other foreign substances could be flushed or blown into the treatment unit.

Metal chips can interfere with the function of pneumatic components. Filters are clogged by foreign substances.

- When assembling, make sure that there are no chips or other foreign substances in the pipes.
- Flush the water pipes.
- Blow out the air ducts.
- Make sure that no further foreign substances get into the pipes and ducts after rinsing or blowing out.

Requirements for the suction system	
Vacuum at supply connection	min. 0,12 bar, max. 0,18 bar
Minimum suction power at supply connection	≥750NI/min
Suction system	Type 1: high flow rate wet or dry suction
Suction pipe	DN40 HT-PP (polypropylene, inside diameter approx. 36.5 mm)
Water drain	DN40 HT-PP (polypropylene, inside diameter approx. 36.5 mm)
Gradient	Min. 10 mm per metre
Wastewater volume	3 l/min

Filter in the treatment unit		maintenance interval	Article number
Particle filter water inlet	50 µm	Replace annually	210623-WBG
Particle filter compressed air inlet	50 µm	Replace annually	210623-LBG
Solid particle filter for the suction system	Mesh size 1 mm	In case of damage, replace at least annually.	514100

Requirements for Supply Connections

①	Air: pipe min. 10x1 mm, angle valve outlet 3/8"
②	Water drain DN40 HT-PP
③	Suction line DN40 HT-PP
④	Power cable 3x1.5 mm ²
④	Equipotential bonding 1x 4 mm ²
④	Control line to suction device 5x1.5 mm ²
⑤	Water: pipe min. 10x1 mm, angle valve outlet 3/8" (2 outlets with 2 stopcocks)

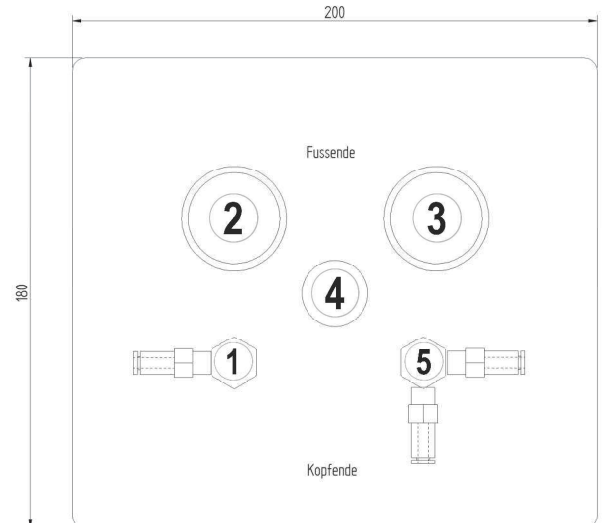

With the L2-SOLO the connections 1, 2, 3, 5 and the control line to the suction device are not needed.

Dimensions in Millimetres

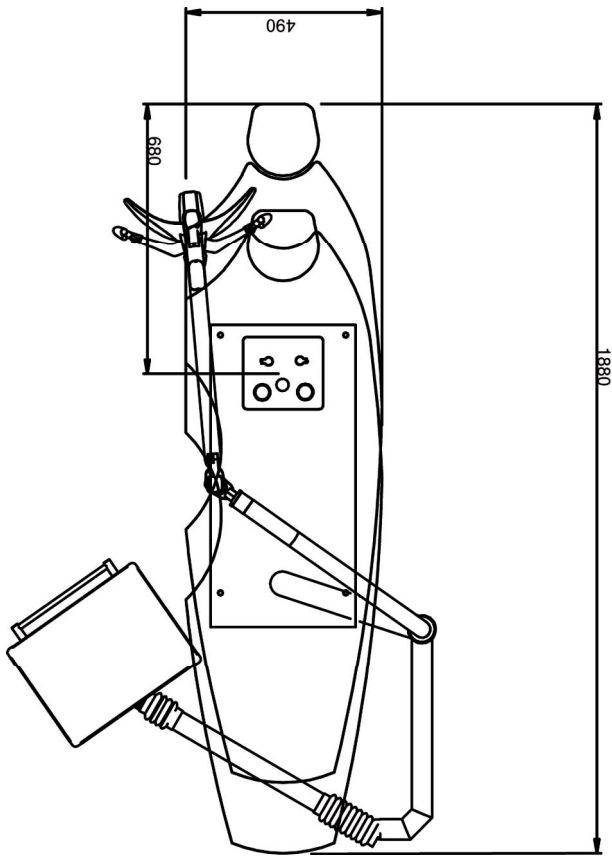

L2-SOLO Version with short back rest

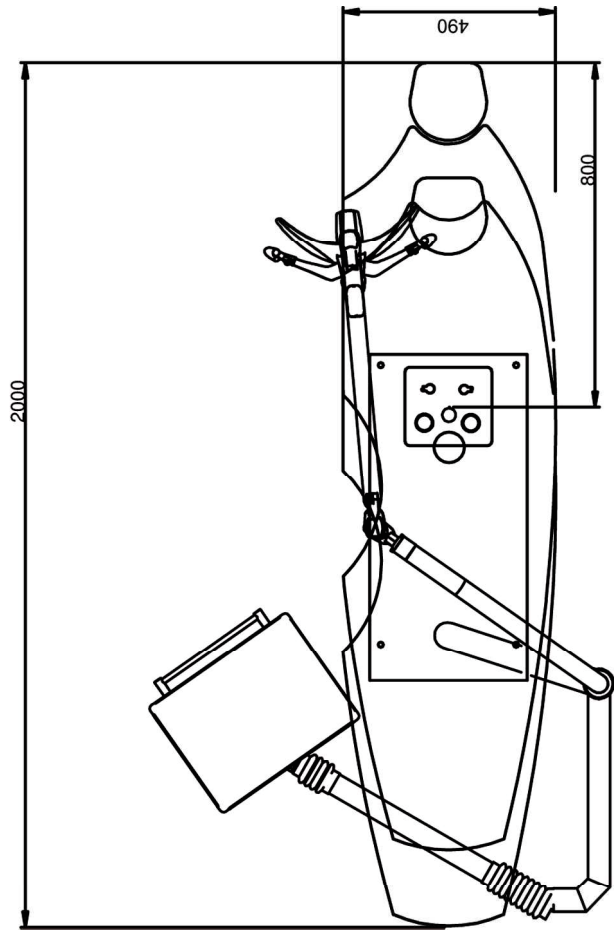

L2-SOLO Version with long back rest

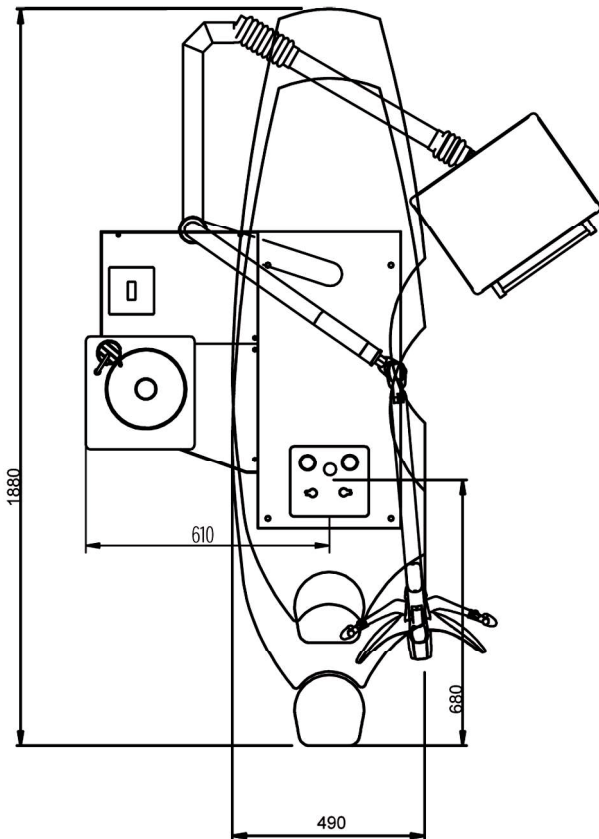

L2-SOLO-S Version with short back rest

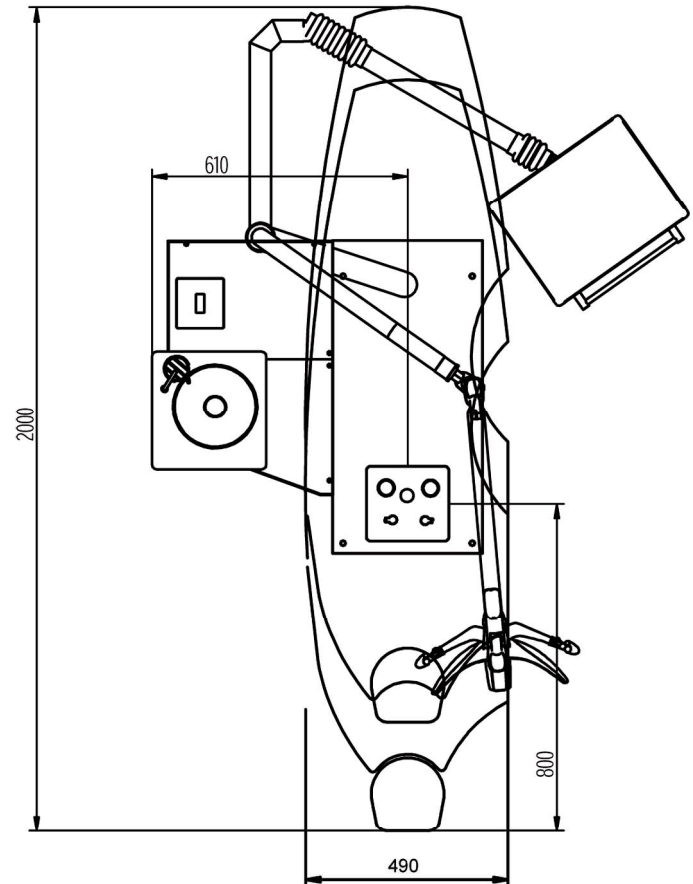

L2-SOLO-S Version with long back rest

Dimensions in Millimetres

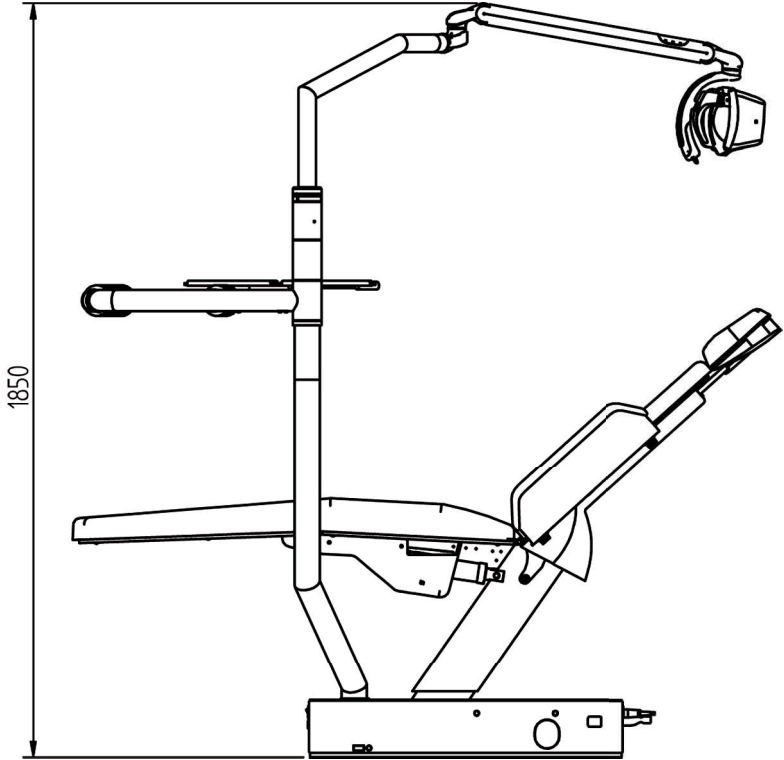

Treatment chair:
lowest position 570 mm
highest position 800 mm

Product Description

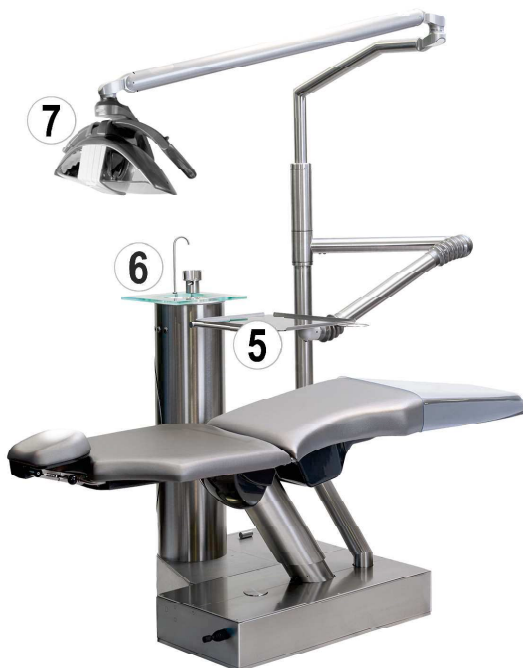
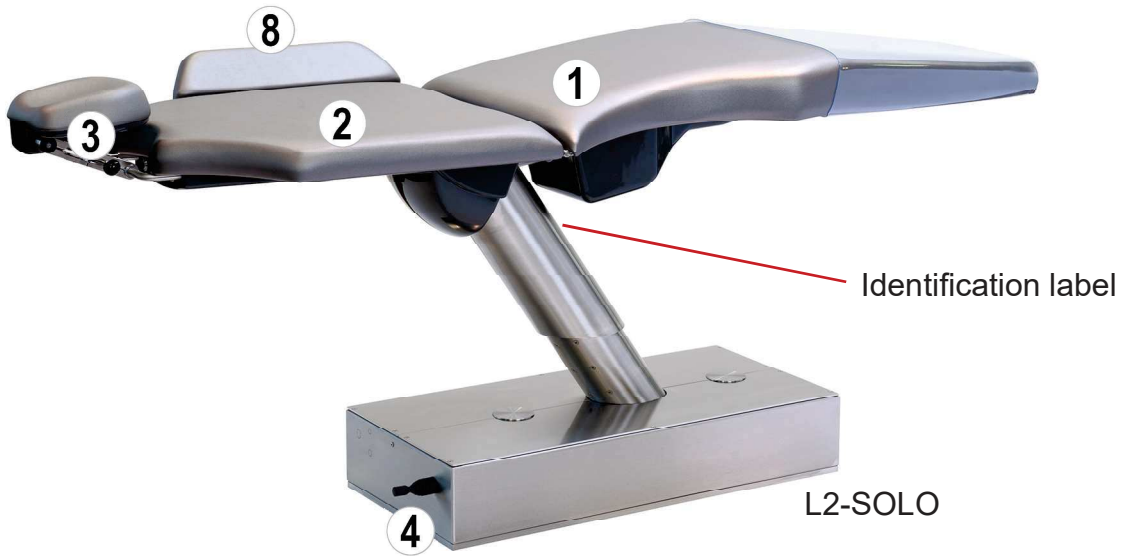

①	Treatment chair, seat
②	Treatment chair, back rest
③	Treatment chair, double-jointed headrest
④	Treatment chair, joystick
⑤	Tray
⑥	Cuspidor
⑦	Operating Lamp LED.light EVA
⑧	Treatment chair, arm rest

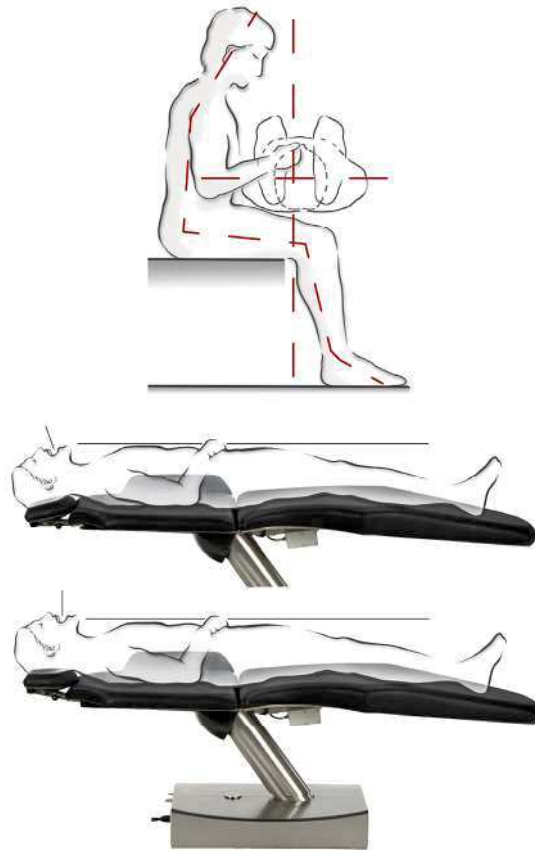

Treating patients in a lying position gives you a clear view of the upper and lower jaw. This optimal working posture is ensured by sufficient legroom. During lower-jaw treatments, the patients are positioned horizontally; for treatments in the upper-jaw region the patient's head is slightly overstretched backwards.

The double-jointed headrest offers stable support for the patient's head at the starting point of the neck muscles. This way the patient is relaxed and does not need to constantly correct his or her position. Treatment of patients in a lying position offers you an optimal view and, consequently, optimal results.

Moving the Treatment Chair

Joystick at the chair base

Move the joystick downwards

> Treatment chair moves downwards.

Move the joystick upwards

> Treatment chair moves upwards.

Move the joystick to the left

> Back rest tilts backwards.

Move the joystick to the right

> Back rest moves to an upright position.

Tap the Joystick Twice

> Treatment chair moves to the entry /exit position.

Tap the joystick twice downwards

> Treatment chair moves to the treatment position p2.

Tap the Joystick Twice to the Left

> Treatment chair moves to the rinsing position and back to the last position when tapping twice again.

Tap the Joystick Twice to the Right

> Treatment chair moves to the treatment position p1.



Joystick

Programme keys at the back rest

Press “p0”

> Treatment chair moves to the position for getting on/off.

Press “p1”

> Treatment chair moves to treatment position p1.

Press “p2”

> Treatment chair moves to treatment position p2.

Press “p3”

> Treatment chair moves to treatment position p3.

Briefly press “lp”

> Treatment chair moves to the rinsing position and after renewed pressing back to the “last position”.



Programme keys

Saving programme keys p0 – p3

For programming the keys, move to the desired programme position manually and then keep the respective programme key pressed for about 3 seconds until you hear a signal tone. Now you have successfully saved your individual treatment position.

Saving programme key lp

Press the “lp” key to move the chair to the rinsing position. By pressing the key “lp” once again, the chair moves back to the previous programme position or to the manually set position. In order to programme the chair, move it manually to the desired rinsing position and then keep the key “lp” pressed for about 3 seconds until you hear a signal tone. Now you have successfully saved your rinsing position.

Moving the Treatment Chair



Emergency-Stop System

Briefly tap the joystick or any programme key at the back rest to stop the active programme immediately.



Programme Run

Press the programme keys "0" and "1p" simultaneously for about 3 seconds until you hear a signal tone. The treatment chair then moves the seat and the back rest into the lowest position. The motion sequence has been reset now.

You can find an application film at www.youtube.com/DKL_Germany.

Video: DKL CHAIRS L2 SERIES FUNKTIONEN TREATMENT CHAIR POSITIONS



LINK: <https://youtu.be/qzRuFbGAuA0>

The treatment chair can optionally be equipped with arm rests. The arm rest on the assistant's side is firmly screwed on. The arm rest on the doctor's side can be removed by loosening the two knurled screws on the back of the back rest.



Pull the release lever up to freely adjust the double-jointed headrest. Press the lever down to fix the position of the double-jointed headrest. The release lever must always be pulled up completely to move the headrest.



Manually extractable double-jointed headrest.



Putting the Treatment Unit into Operation



- > Before putting the device into initial operation and after downtimes (weekends, (public) holidays etc.), flush the water lines intensively.
- > Press the cup fill button several times before starting work.

Activating / Deactivating the Treatment Unit



The treatment unit is equipped with a power switch ① on the chair base. The power switch connects the treatment unit with the power supply.

In the event of longer downtimes, the treatment unit should be disconnected from the power supply.

The treatment unit contains a device fuse ②.

Switch on the treatment unit at the power switch. The power switch lights up green.

Operating Lamp LED.light EVA

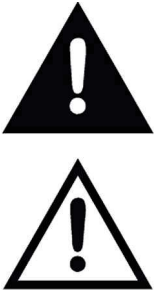

For the intended use, please observe the operating instructions issued by FARO: USER MANUAL EVA

When swivelling and moving the operating lamp, always make sure that no objects or persons are in the swivelling range of the arm system. Otherwise, personal injury or property damage may occur.

In order to move the operating lamp only touch its handles!

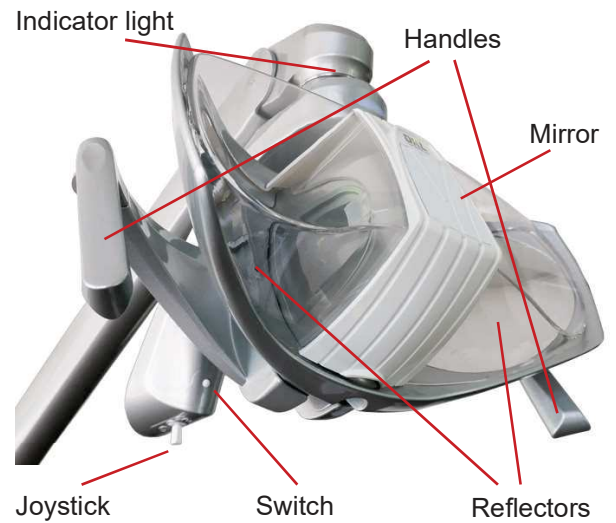

Switching on/off on the joystick:
Push right or left



Decrease the light intensity on the joystick:
Push right and keep pushed until desired intensity is reached.

Increase the light intensity on the joystick:
Push left and keep pushed until desired intensity is reached.



light intensity indicator

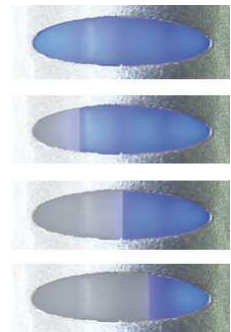

change in light intensity

Operating Lamp LED.light EVA

Changing the color temperature via the switch:

Every time a double click is performed, the colour temperature in Kelvin (Tk) of the light changes. Repeat the procedure until the desired colour temperature is shown on the indicator light. 2 beeps will inform the user that Tk is changing.



Indicator light
yellow
4000 Kelvin



Indicator light
white
5000 Kelvin



Indicator light
blue
5700 Kelvin



Composave setting



Composave setting on the joystick:
Push forwards or backwards.



Composave setting on the switch:
Single Click.



Acoustic signal and
indicator light
switches to orange.

Mirror

Loosen the plastic cover at the front of the protective cap by lightly pressing on its upper end.

On the back of the cover there is a mirror. Attach the mirror to the plastic cover.



You can find an application film at www.youtube.com/DKLGermany.
Video: DKL CHAIRS L2-D2 SERIES FUNCTIONS LED.LIGHT OPERATING LAMP EVA

LINK: <https://youtu.be/vaKW9RdjtLM>

Cleaning and disinfection of the Operating Lamp LED.light EVA

Pull the protective cap towards you to remove it for cleaning.



Cleaning and care

The reflectors must be cleaned with cotton wool and ethyl alcohol. Do not use detergents that contain surfactants or water-repellent substances (staining).



Cleaning, disinfection and Sterilisation of the handles

To remove the handles, turn the handle lock on the handles and pull off the handles. To mount the handles, reattach them and push them to the limit. Then lock the handle lock.



Cleaning and Disinfection of the handles

Before sterilising the handles, they must be decontaminated and disinfected.



The handles cannot be disinfected by thermo-disinfection.



Sterilisation of the handles:

The handles must be packaged in compliance with EN 868-5. The handles can be sterilised with standard cycles 121°/134° C up to two hundred (200) cycles or however up to loss of the mechanical performance.



Cycle EN 13060	Temperature	Pressure	Holding time minimum
B	121°C	207 kPa	15 min.
B	134°C	308 kPa	3 min.



Warning against danger of wear and corrosion and falling suspended mass.

For all metal or plastic parts it is strictly forbidden to use substances that are abrasive, corrosive, acids, substances containing chlorine or chloride ions, phosphorous or phosphorous ions or detergents with Trilene base, petrol, white spirit, chlorine or similar.

Do not use detergents-disinfectants containing the following substances to clean plastic parts:

Ammonium Hydroxide, Sodium Hydroxide, Hydrogen peroxide, Ammonium Chloride, Methylene Chloride, Methyl Alcohol, acids and corrosive substances of all kinds.

It is forbidden to directly spray any chemical substance on the device.

Tray

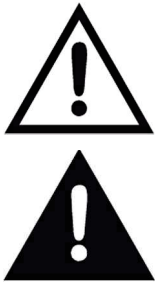

The tray should be set correctly for your standard equipment and thus remain in its desired position. The maximum load of the tray is 2 kg. Do not lean on the tray.

Pull back the bellows until the adjusting screw (1) is visible. Place your standard equipment on the tray (max. 2 kg) and move the tray into a horizontal position.

Set the adjusting screw (1) so that the arm remains in the horizontal position (with a slight upward tendency).

Turn the adjusting screw in the „ + „ direction = high weight.

Turn the adjusting screw in the „ - „ direction = low weight

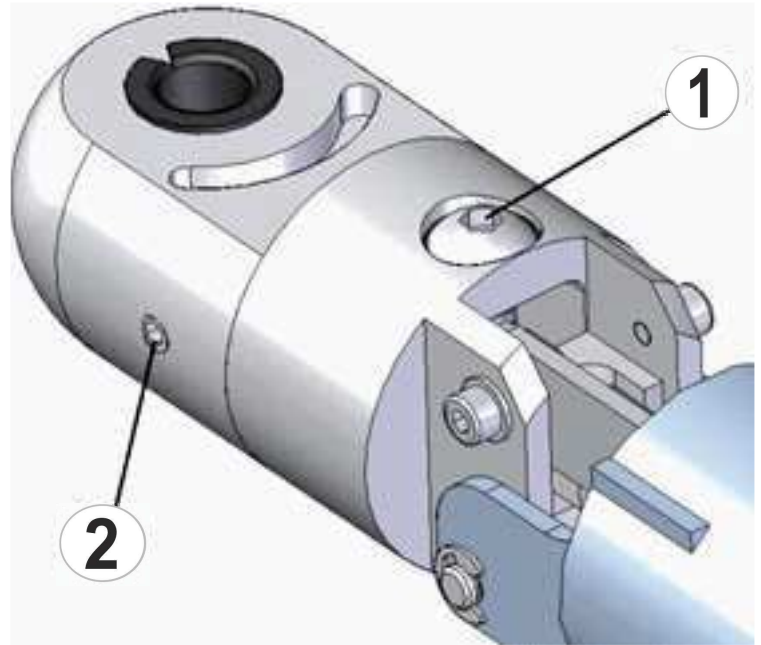

Secure the 3 grub screws (2) with safety lacquer (blue).

With the adjusting screw, the tray can be aligned in its radially horizontal position.

Pull back the bellows until the adjusting screw (1) is visible. Move the tray into a horizontal position.

Secure the adjusting screw (1) for the inclination with thread locking fluid (blue).

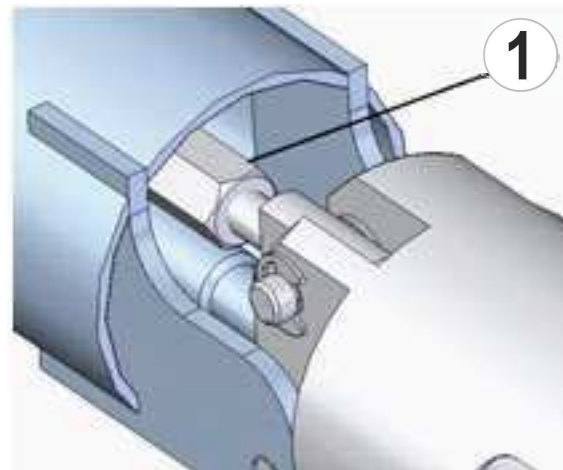

You can find an application film at [www.youtube DKL Germany](https://www.youtube.com/watch?v=DKL_Germany).
Video: DKL CHAIRS L2-D2-RANGE TRAY SETTINGS

LINK: <https://youtu.be/r-Y14eEYtqI>

Suction System



For the intended use, please observe the operating instructions issued by DÜRR Dental:

- > Cuspidor valve, Version 3
- > CAS 1 operating instructions issued by DÜRR Dental
- > CS 1 operating instructions issued by DÜRR Dental, depending on the equipment and design of the suction system.



Open the door of the cuspidor fountain by pulling the handle. Depending on the equipment and design of the suction system, you will find the following in the cuspidor:

- > Cuspidor valve, Version 3 (wet suction)
- > CAS 1 operating instructions issued by DÜRR Dental (dry suction)
- > CS 1 operating instructions issued by DÜRR Dental (dry suction)

Cleaning and Disinfection of the Surfaces

Hygiene and Care of the Stainless-Steel Surfaces

The regular cleaning of stainless-steel surfaces is recommended for hygienic as well as aesthetic reasons and serves to remove grease stains or finger marks. These can be easily removed with commercially available chlorine- and acid-free stainless-steel cleaners. We recommend applying Prestan to the surface in question.

Most stainless-steel care products contain silicone oil. Using these products can make your work a lot easier. They effortlessly remove any finger marks, but do not necessarily prevent new ones. Depending on the intensity of use, the protective layer remains in place for a few days. Microfibre cloths slightly moistened with water have also proved to be very effective.

Never use abrasive agents such as scouring powder, scouring milk or steel wool as these may cause scratches. Brushed surfaces must always be wiped in the direction of the finish. For this purpose, we recommend using a microfibre cloth. After cleaning, we recommend always wiping stainless-steel surfaces dry with a lint-free cloth to remove water stains or residual cleaning agent.

Disinfection of Stainless-Steel Surfaces

Do you put emphasis on a germ-free surface? Here, too, stainless steel proves to be extremely robust. Any commercially available chlorine-free disinfectant can be used.

Tests have shown that stainless steel is considerably easier to disinfect than other materials and even a lot less disinfectant is required in order to meet hygiene requirements.

The Most Important Facts at a Glance:

Effective and generally safe to use on surfaces are

- Soft sponges or microfibre cloths,
- Soapy water (to remove greasy stains),
- Diluted vinegar (to remove lime),
- Sodium bicarbonate (to remove coffee stains),
- Soda (to remove tea stains),
- Alcoholic solvents (to remove glue) and
- Special stainless-steel care products (for cleaning and conservation).



Caution is called for with

- Disinfectants containing chlorine and cleaning agents containing bleach (risk of corrosion).



Never use:

- Scrubbing sponges (scratches and extraneous rust),
- Scouring powder (scratches)
- Silver polish (corrosive).

Cleaning and Disinfection of the Surfaces

DentaClean: cleaning agent for imitation leather and plastic surfaces



Properties

DentaClean gently and easily cleans soiled imitation leather and plastic surfaces.

Use

Test on a hidden area first. We recommend cleaning the chair upholstery at the end of every treatment day. This is particularly important with light colours; any visible soiling must be removed immediately. Use the provided sponge to apply DentaClean in circular motions to the surfaces to be cleaned. Then remove moisture and dirt with a soft, absorbent cloth. For a thorough cleaning, use a cleaning brush instead of the sponge twice a week. Finally, seal with DentaProtect. Upholstery that is treated regularly and properly with DentaProtect is easier to clean!

DentaProtect: Care and protection for your imitation leather upholstery



Properties

DentaProtect is a product for caring and protecting heavy-duty imitation leather upholstery. Sealing the surface, it acts as a micro-binding agent and protects the upholstery from damage due to abrasion, soiling and also discolouration by non-fixed colourants in clothes.

Application

After the thorough end of the day cleaning cycle, apply the DentaProtect sealing evenly to the dry upholstery. You need 1 – 2 wipes for the complete upholstery set of your treatment chair. Close the box immediately after taking out the wipes.

Disinfection of medical artificial leather



Products: Wipe disinfection for plastics.

What: Upholstery, Covers (trays, panels etc.).

When: After every patient.

Cleaning and Disinfection of the Surfaces

DKL
REINIGUNG & PFLEGE

DKL GmbH
An der Ziegelei 4 • 37124 Rosdorf • Germany
Tel. +49 (0)551-50 06 0 • info@dkl.de
Shop: www.dkl.de



Cleaning and Care

Care set

1 x DentaClean 200 ml spray foam cleaner (article DC200)
1 x DentaProtect wipe dispenser box (article DP100)
1 x cleaning brush, 3 x cleaning sponges

Article number PSET

DentaClean 1000ml
Refill bottle for spray foam cleaner

Article number DC1000

DentaClean 200ml
Spray foam cleaner incl. 2 x cleaning sponges

Article number DC200

DentaProtect wipe dispenser box
100 wipes in a disposable sealing bag

Article number DP100

DentaProtect wipe dispenser set
6 wipe dispenser boxes with 100 wipes each in a disposable sealing bag

Article number DP600

Cleaning brush set, 4 pieces

Article number RB4

Cleaning sponge set, 8 pieces

Article number RS8



You can find an application film at www.youtube.com/DKLGermany.
Video: MEDICAL UPHOLSTERY – CLEANING DISINFECTION PROTECTION

LINK: <https://youtu.be/kM2E0kM6J1M>

Maintenance and Inspection



In order to ensure the operational and functional reliability of your treatment unit and to avoid damage due to wear and tear it is necessary to perform maintenance once a year. Maintenance is carried out by an authorised technician of your specialist dealer or a DKL CHAIRS technician.

The work steps to be performed and the parts to be replaced are specified in the document "Maintenance Log". The tasks that were performed have to be entered in the maintenance log, which is part of the medical devices logbook.

Safety Inspections



Dental units are designed in such a way that a first fault does not present a hazard to patients, operators or third parties. Therefore, it is important to detect such faults before a second fault occurs, which may result in a hazard.

For this reason, safety inspections should be carried out every 3 years to detect electrical faults in particular (e.g. faulty electrical insulation). These checks are carried out by an authorised technician of your specialist dealer or a DKL CHAIRS technician.

The work steps to be performed are specified in the document "Safety Inspections". The measured values have to be documented.

Safety inspections have to be carried out when putting your treatment unit into initial operation, after expansion or retrofitting activities on your treatment unit and after repair jobs. The safety inspections are carried out in accordance with DIN EN 62353.



The treatment unit may only be operated when the safety checks have been passed.

Warranty Declaration



12 Months Warranty

This DKL medical product has been manufactured with the utmost care by highly qualified specialists. Multifarious checks and inspections ensure faultless performance. Please note that warranty claims will only be accepted if all the instructions in this operating manual have been observed.

DKL as the manufacturer shall be liable for material and manufacturing faults within a warranty period of 12 months from the date of purchase. Accessories and consumables (seals, filters, lamps and suction tubes) are excluded from this warranty. We do not accept liability for damages caused by improper treatment or repair work carried out by third parties that are not authorised by DKL!

Any warranty claims must be filed with the supplier or an authorised DKL service partner and the sales slip must be enclosed. Any performance of this warranty does not extend the warranty period.

To protect your warranty claims and guarantee safe operation, medical devices must be installed properly, and staff must be instructed. To be able to proof this, information for assembly, initial start-up and instructions must be documented. For this purpose, please use our L2-D2 series certificate of delivery. After putting the device into operation, please return the completed certificate to us as proof.

Waste Disposal



Make sure that the parts that are being disposed of are not contaminated.



Observe your local and national laws, guidelines, standards and regulations for disposal.

- > Medical devices
- > Waste electrical and electronic equipment



Further information on disposal can be found at <http://dkl.de>



Disposal and recycling of DKL transport packaging is carried out within the scope of the Dual System via the local waste disposal and recycling companies.

DKL transport packaging returned by customers at their own expense is supplied by DKL to the recycling companies set up for this purpose without further costs and without reimbursement.

EMC - Manufacturer's Declaration for the Model L2-SOLO

- **WARNING:** The use of accessories that do not conform to the manufacturer's specifications may result in higher interference levels and/or lower interference immunity.
- Operate the equipment in a location as far away as possible from equipment that emits electrical and magnetic disturbances. If it is necessary to operate the device in the immediate vicinity of other devices, make sure that the system functions correctly.

BASIC SAFETY

BASIC SAFETY is ensured if it meets the safety requirements of the IEC 60601-1 standard, in particular the requirements against: electrical shock, mechanical hazards and hazards due to excessive temperatures.

ESSENTIAL PERFORMANCE

The dental unit has no direct clinical function or essential performance according to IEC 60601-1, IEC 80601-2-60, 201.4.3 ESSENTIAL PERFORMANCE.

Performance limitations are permitted according to the following criteria. This is considered in the risk analysis of the system.

Criterion A

The dental unit will withstand the test without damage or other interference. During and after the test, the device will operate perfectly within the specified limits. Basic safety is guaranteed throughout.

Criterion B

The dental unit will withstand the test without damage or other interference. After the test, the device will operate perfectly within the specified limits. Basic safety is guaranteed throughout.

Criterion C

A temporary malfunction is permitted if the function resets itself or if it can be restored by user intervention. Basic safety is guaranteed throughout.

Intended operating environment

Intended operating environments are typical professional health care facilities and areas of home health care.

Technical description

This dental unit has been tested and developed to meet the EMC behaviour in the specified environment. This includes special EMC-filters to reduce the radiation of electromagnetic waves as defined in IEC 60601-1-2.

Please read and follow all technical documentation to avoid adverse events for the patient or user.

IEC STANDARD 60601-1-2:2014, 4th Edition

This device is approved for use in a specific electromagnetic environment. The customer or user of the device must ensure that it is used in an electromagnetic environment in accordance with the description given below.

Emission Measurement	Agreement	Guidelines Regarding the Electromagnetic Environment
RF-emission according to CISPR 11	Group 1	This device uses RF-energy for internal functions only. RF-emissions are therefore very low, and it is unlikely that other nearby electronic equipment will be disturbed. The device is suitable for use in all environments, including residential areas, and approved for direct connection to the public low-voltage network for residential areas.
RF-emission according to CISPR 11	Class B	
Harmonics according to IEC 61000-3-2	Class A	
Voltage fluctuations/ flicker according to IEC 61000-3-3	met	

Interference Immunity Test	IEC 60601-test level	Compliance level	Electromagnetic Environment - Guidelinesf
Electrostatic Discharge (ESD) according to IEC 61000-4-2	± 8 kV contact discharge ±2, 4, 8, 15 kV air discharge	± 8 kV contact discharge ±15 kV air discharge	The floor should be wood, concrete or tiles. If the floor is covered with synthetic material, the relative humidity should be at least 30%. Criterion B
Fast transient electrical disturbances/bursts according to IEC 61000-4-4 (only for V 300/600)	± 2 kV for mains 100 kHz repeat rate	± 2 kV for mains 100 kHz repeat rate	The quality of the mains power supply should meet the requirements for a normal commercial or clinical environment. Criterion B
Surge voltages according to IEC 61000-4-5 (only for V 300/600)	± 0,5 kV , ± 1 kV L to N ± 0,5 kV , ± 1 kV ± 2 kV L to GND	± 1 kV L to N ± 2 kV L to GND	The quality of the mains power supply should meet the requirements for a normal commercial or clinical environment. Criterion B
Voltage dips, short-term interruptions and voltage fluctuations of the mains supply lines according to IEC 61000-4-11 (only for V 300/600)	0 % UT 0°,45°,90°,135°,180°,225°,270°,315° 0 % UT 0° 0% 70 % UT 0 % UT 0%	0 % UT for 1/2 Period 1 Period 25 /30 Periods (50/60Hz) 250/300 Periods (50/60Hz) for 5 s	The quality of the mains power supply should meet the requirements for a normal commercial or clinical environment. If the user of the product requires continuous operation even with interruptions of the power supply, the product should be connected to an uninterruptible power supply. Criterion A (max. mains voltage) Criterion B (min. mains voltage) Criterion A (max. mains voltage) Criterion B (min. mains voltage) Criterion A (max. mains voltage) Criterion B (min. mains voltage) Criterion A (max. mains voltage) Criterion B (min. mains voltage)
Magnetic field at the mains frequency (50/60 Hz) according to IEC 61000-4-8	30 A/m	30 A/m	Magnetic fields at the mains frequency should have levels typical of an application in a commercial or clinical environment.

Note: UT is the alternating mains voltage prior to the application of the test level.

Specifications for Enclosure Port Immunity

Immunity Test	Test condition	IEC 60601 level of conformity	Electromagnetic Environmental Recommendation
Radiated electromagnetic fields from high-frequency wireless communication devices IEC 61000-4-30-4-3	10 V/m 80 MHz – 2,7 GHz 80% AM 1kHz	10 V/m 80 MHz – 2,7 GHz	The quality of the main power supply should correspond to the one for a professional health care facility and be appropriate regarding the environment in areas of domestic health care. Criterion A
	385MHz (18Hz pulse modulation)	27 V/m	
	450MHz (FM+/-5KHz deviation 1kHz sine or 18Hz pulse modulation)	28 V/m	
	710MHz (217Hz PM)	9 V/m	
	745MHz (217Hz PM)	9 V/m	
	780MHz (217Hz PM)	28 V/m	
	810MHz (18Hz PM)	28 V/m	
	870MHz (18Hz PM)	28 V/m	
	930MHz (18Hz PM)	28 V/m	
	1720MHz (217Hz PM)	28 V/m	
	1845MHz (217Hz PM)	28 V/m	
	1970MHz (217Hz PM)	28 V/m	
	2450MHz (217Hz PM)	28 V/m	
	5240MHz (217Hz PM)	9 V/m	
5500MHz (217Hz PM)	9 V/m		
5785MHz (217Hz PM)	9 V/m		

Interference immunity test	IEC 60601-test level	Compliance level	Electromagnetic environment - guidelines
Conducted RF-disturbance variables according to IEC 61000-4-6 (only for V 300/600) Radiated RF-disturbance variables and near fields from wireless communication equipment according to IEC 61000-4-3	3 Veff 150 kHz to 80 MHz 10 V/m 80 MHz to 2,7 GHz	10 Veff 10 V/m	The distance between portable or mobile RF-communications equipment and parts of the product, including cables, should not be less than the recommended protective distance calculated with the equation applicable to the transmission frequency. Recommended protective distance: $d = 1,2\sqrt{P}$ $d = 1,2\sqrt{P}$ for 80 MHz to 800MHz $d = 2,3\sqrt{P}$ for 800 MHz to 2.7 GHz Here P is the maximum nominal power output of the transmitter in watts (W) according to the transmitter manufacturer's specifications, and d is the recommended distance in metres (m). The field strength of permanently installed RF-transmitters, which was determined by an electromagnetic location test ^a should not exceed the level ^b permitted in any frequency range. Interference may occur in the immediate vicinity of equipment marked with the following symbol: 

Note 1: At 80 MHz and 800 MHz respectively, the larger frequency range applies.

Note 2: These guidelines may not apply to all situations. The propagation of electromagnetic waves is affected by the absorption and reflection of structures, objects, people and animals.

^a The field strength of permanently installed transmitters, such as base stations for radio telephony (cordless or mobile phones), mobile radio stations, amateur radio transmitters, AM and FM radio and television transmitters, cannot theoretically be calculated with absolute accuracy. To determine the electromagnetic fields generated by fixed RF-transmitters, an electromagnetic site inspection should be carried out. If the measured field strength at the location where the device is used exceeds the permissible RF-field strength specified above, the instrument should be observed. Additional measures may be necessary, e.g. reorientation or change of location of the device.

^b In the frequency range between 150 kHz and 80 MHz, the field strength should be less than 3 V/m.

Manufacturer's Declaration - Electromagnetic Interference Immunity III

The device is approved for use in a specific electromagnetic environment.

The customer or user of the device must ensure that it is used in an electromagnetic environment as described below.

Interference Immunity Test	IEC 60601-test level	Compliance level	Electromagnetic environment – guidelines
Fluctuations in the mains frequency and mains voltage according to IEC 601-1, section 10.2.2. a (only for V 300/600)	Nominal frequency: up to 100 Hz: variations of ± 1 Hz of the nominal frequency; variations of $\pm 10\%$ Hz of the nominal voltage	Nennfrequenz: bis zu 100 Hz: Schwankungen von ± 1 Hz der Nennfrequenz; Schwankungen von $\pm 10\%$ Hz der Nennspannung	The quality of the mains voltage supply should meet the requirements of a normal commercial or clinical environment.

Manufacturer's Declaration - Recommended Protective Distances between Portable or Mobile RF-Communication Equipment and the Device

The device is intended for use in an electromagnetic environment where the radiated RF-disturbance variables are checked. The customer or user of the device can help to prevent electromagnetic interference by maintaining a minimum distance between portable and mobile RF-communication equipment (transmitters) and the device in accordance with the following recommendations, which are based on the maximum output power and frequency of the communication device.

Maximum nominal power of the transmitter in watts (W)	Protective distance as a function of the frequency of the transmitter in metres (m)		
	150 kHz to 80 MHz $d = 1,2\sqrt{P}$	80 MHz to 800 MHz $d = 1,2\sqrt{P}$	800 MHz to 2,5 GHz $d = 2,3\sqrt{P}$
0,01	0,12	0,12	0,23
0,1	0,38	0,38	0,73
1	1,2	1,2	2,3
10	3,8	3,8	7,3
100	12	12	23

For transmitters with a maximum output power not specified above, the recommended safety distance d in meters (m) can be calculated with an equation from the transmitter frequency and the maximum nominal output power P of the transmitter in watts (W) based on the transmitter manufacturer's specifications.

Note 1: At 80 MHz and 800 MHz respectively, the larger frequency range applies.

Note 2: These guidelines may not apply to all situations. The propagation of electromagnetic waves is affected by the absorption and reflection of structures, objects, people and animals.

ATTENTION: The use of this device directly adjacent to or coupled to another unit should be avoided as it may lead to unintentional behaviour. However, if this arrangement is unavoidable, both devices must be observed to verify that they are functioning normally.

CAUTION: Portable RF-communication equipment (including antenna cables or external antennas) should not be closer than 30 cm to the ME-equipment or ME-system, including those cables specified by the manufacturer. Otherwise, a power limitation of the device could be caused.

Spittoon valve 3

EN

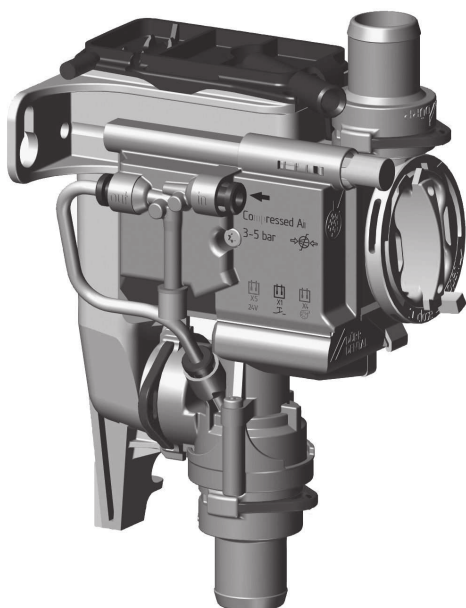

Installation and operating instructions

CE

7560100003L02



 **DÜRR
DENTAL**

2102V003

Contents



Important information

1 About this document	2
1.1 Warnings and symbols	2
1.2 Copyright information	3
2 Safety	3
2.1 Intended purpose	3
2.2 Intended use	3
2.3 Improper use	3
2.4 General safety information	4
2.5 Systems, connection with other devices	4
2.6 Specialist personnel	4
2.7 Electrical safety	4
2.8 Only use original parts	4
2.9 Transport	4
2.10 Disposal	4



Product description

3 Overview	5
3.1 Scope of delivery	5
3.2 Optional items	5
3.3 Wear parts and replacement parts	5
4 Technical data	6
4.1 Type plate	10
4.2 Evaluation of conformity	10
5 Operation	11
5.1 Operating function	11
5.2 Cleaning function	11



Assembly

6 Requirements	12
6.1 Setup options	12
6.2 Preparing for the installation	12
6.3 Hose materials	12

6.4 Information about electrical connections	12
--	----

7 Installation	13
7.1 Installation overview	13
7.2 Installation of the spittoon valve	14
7.3 Establishing the compressed air connection	14
7.4 Electrical connections	14
7.5 Circuit diagram	16
8 Commissioning	17



Usage

9 Disinfection and cleaning	18
9.1 Spittoon valve	18
9.2 Suction system	18
10 Maintenance	19



Troubleshooting

11 Tips for operators and service technicians	20
12 Transporting the unit	21

! Important information

1 About this document

These installation and operating instructions represent part of the unit.

 If the instructions and information in these installation and operating instructions are not followed, Dürr Dental will not be able to offer any warranty or assume any liability for the safe operation and the safe functioning of the unit.

The German version of the installation and operating instructions is the original manual. All other languages are translation of the original manual.

1.1 Warnings and symbols

Warnings

The warnings in this document are intended to draw your attention to possible injury to persons or damage to machinery.

The following warning symbols are used:

 General warning symbol

 Warning – dangerous high voltage

 Biohazard warning

The warnings are structured as follows:

 **SIGNAL WORD**
Description of the type and source of danger
Here you will find the possible consequences of ignoring the warning
› Follow these measures to avoid the danger.

The signal word differentiates between four levels of danger:

- › **DANGER**
Immediate danger of severe injury or death
- › **WARNING**
Possible danger of severe injury or death
- › **CAUTION**
Risk of minor injuries
- › **NOTICE**
Risk of extensive material/property damage

Other symbols

These symbols are used in the document and on or in the unit:

 Note, e.g. specific instructions regarding efficient and cost-effective use of the unit.

 Refer to Operating Instructions.

 Wear protective gloves.

 Wear protective goggles.

 Use a face mask.

 Refer to the accompanying electronic documents.

 Cleaning button

 Air

 Vacuum

 Manufacturer

 Order number

 Serial number

1.2 Copyright information

All circuits, processes, names, software programs and units mentioned in this document are protected by copyright.

The Installation and Operating Instructions must not be copied or reprinted, neither in full nor in part, without written authorisation from Dürr Dental.

2 Safety

Dürr Dental has designed and constructed this unit so that when used properly and for the intended purpose it does not pose any danger to people or property.

Despite this, the following residual risks can remain:

- › Personal injury due to incorrect use/misuse
- › Personal injury due to mechanical effects
- › Personal injury due to electric shock
- › Personal injury due to radiation
- › Personal injury due to fire
- › Personal injury due to thermal effects on skin
- › Personal injury due to lack of hygiene, e.g. infection

2.1 Intended purpose

The spittoon valve is designed for installation in a treatment unit in dental surgeries or dental clinics.

The installation of the spittoon valve into a treatment unit helps to avoid suction noises emanating from the spittoon.

2.2 Intended use

The device is designed to be installed between the spittoon and the suction line. The spittoon valve may only process media (e.g. water, saliva, polishing powder, solid materials like fillers, etc.) from the the spittoon.

The spittoon valve can operate max. 1 dental work place.

2.3 Improper use

Any use of this appliance / these appliances above and beyond that described in the Installation and Operating Instructions is deemed to be incorrect usage. The manufacturer cannot be held liable for any damage resulting from incorrect usage. The operator will be held liable and bears all risks.

This includes:

- › Use of silicones, sludge, gypsum or similar substances from the practice.
- › Cleaning and disinfection with chlorine-containing chemicals (such as, e. g., sodium hypochloride).

 Important information

2.4 General safety information

- › Always comply with the specifications of all guidelines, laws, and other rules and regulations applicable at the site of operation for the operation of this unit.
- › Check the function and condition of the unit prior to every use.
- › Do not convert or modify the unit.
- › Comply with the specifications of the Installation and Operating Instructions.
- › The Installation and Operating Instructions must be accessible to all operators of the unit at all times.

2.5 Systems, connection with other devices

Additional devices connected with medical electrical devices must be proven to conform with their corresponding IEC or ISO standards. All configurations must continue to comply with the standard requirements for medical systems (see IEC 60601-1).

Whoever connects additional devices to medical electrical devices automatically becomes the system configurator and is responsible for ensuring that the system corresponds with the standard requirements for systems. Local laws take priority over the requirements outlined above.

2.6 Specialist personnel

Operation

Unit operating personnel must ensure safe and correct handling based on their training and knowledge.

- › Instruct or have every user instructed in handling the unit.

Installation and repairs

- › Installation, readjustments, alterations, upgrades and repairs must be carried out by Dürr Dental or by qualified personnel specifically approved and authorized by Dürr Dental.

2.7 Electrical safety

- › Comply with all the relevant electrical safety regulations when working on the unit.
- › Never touch the patient and unshielded plug connections on the device at the same time.
- › Replace any damaged cables or plugs immediately.

2.8 Only use original parts

- › Only use accessories and optional items that have been recommended or specifically approved by Dürr Dental.
- › Only use only original wear parts and replacement parts.

2.9 Transport

The original packaging provides optimum protection for the unit during transport.

If required, original packaging for the unit can be ordered from Dürr Dental.



Dürr Dental will not accept any responsibility or liability for damage occurring during transport due to the use of incorrect packaging, even where the unit is still under guarantee.

- › Only transport the unit in its original packaging.
- › Keep the packing materials out of the reach of children.

2.10 Disposal



The unit may be contaminated. Instruct the company disposing of the waste to take the relevant safety precautions.

- › Decontaminate potentially contaminated parts before disposing of them.
- › Uncontaminated parts (e.g. electronics, plastic and metal parts etc.) should be disposed of in accordance with the local waste disposal regulations.
- › If you have any questions about the correct disposal of parts, please contact your dental trade supplier.

3 Overview

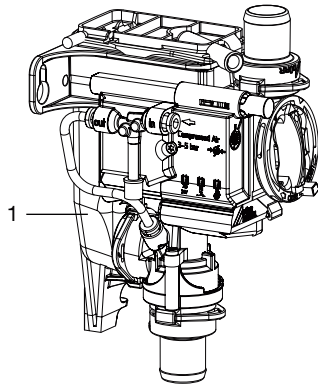

1 Spittoon valve

3.1 Scope of delivery

The following items are included in the scope of delivery (possible variations due to country-specific requirements and/or import regulations):

Spittoon valve 3 7560700xxx

› Spittoon valve

3.2 Optional items

The following optional items can be used with the device:

Switch control panel 7560-520-00

3.3 Wear parts and replacement parts

The following working parts need to be changed at regular intervals (refer to the "Maintenance" section):

Protective strainer 0700-702-06E



Information about replacement parts is available from the portal for authorised specialist dealers at: www.duerrdental.net.

4 Technical data

Electrical data

Safety low voltage	V	24 AC/DC
Frequency	Hz	50/60
Nominal current	A	0.1
Rated power	W	2.4
Type of protection		IP 21

Electrical data, suction unit relay

Switching voltage		
min.	V	0.03 DC
max.	V	30 DC
Switching current		
min.	mA	10
max.	A	2

Connections

Supply and waste water connection		
DürrConnect	mm	Ø 20
Collection vessel vent connection	mm	Ø 9
Compressed air connection	mm	Ø 4

Media

Compressed air		
min.	bar / MPa	3 / 0.3
max.	bar / MPa	5 / 0.5
Fluid flow rate, max.	l/min	3.5
Fluid temperature, max.	°C	35
Suction system pressure		
max.	mbar/hPa	-200
Absolute	mbar/hPa	800

General data

Duty cycle	%	40
Weight	g	240
Dimensions (H x W x D)	mm	143 x 74 x 112

Ambient conditions during storage and transport

Temperature	°C	-30 to +60
Relative humidity	%	< 95

Ambient conditions during operation

Temperature	°C	+10 to +40
Relative humidity	%	< 70

Ambient conditions during operation

Air pressure	hPa	700 - 1060
--------------	-----	------------

**Electromagnetic compatibility (EMC)
Interference emission measurements**

High-frequency emissions in accordance with CISPR 11		Group 1 Class B
Interference voltage at the power supply connection CISPR 11:2009+A1:2010		Compliant
Electromagnetic interference radiation CISPR 11:2009+A1:2010		Compliant
Emission of harmonics IEC 61000-3-2:2005+A1:2008+A2:2009		N/A
Voltage changes, voltage fluctuations and flicker emissions IEC 61000-3-3:2013		N/A
N/A = not applicable		

**Electromagnetic compatibility (EMC)
Interference immunity measurements on the supply input**

Immunity to fast electrical transients/bursts – AC mains voltage IEC 61000-4-4:2012 ± 2 kV 100 kHz repetition rate		Compliant
Immunity to surges, line-to-line IEC 61000-4-5:2005 ± 0.5 kV, ± 1 kV		Compliant
Immunity to surges, line-earth IEC 61000-4-5:2005 ± 0.5 kV, ± 1 kV, ± 2 kV		N/A
Immunity to conducted disturbances, induced by radio-frequency fields – AC mains voltage IEC 61000-4-6:2013 3 V 0.15–80 MHz 6 V ISM frequency bands 0.15–80 MHz 80% AM at 1 kHz		Compliant
Immunity to voltage dips, short interruptions and voltage variations IEC 61000-4-11:2004		Compliant
N/A = not applicable		

EN

**Electromagnetic compatibility (EMC)
Interference immunity measurements SIP/SOP**

Immunity to electrical fast transients/bursts – I/O, SIP/SOP ports IEC 61000-4-4:2012 ± 1 kV 100 kHz repetition rate	Compliant
Immunity to impulse voltages, conductor to earth IEC 61000-4-5:2005 ± 2 kV	N/A
Immunity to conducted disturbances, induced by radio-frequency fields – SIP/SOP ports IEC 61000-4-6:2013 3 V 0.15–80 MHz 6 V ISM frequency bands 0.15–80 MHz 80% AM at 1 kHz	Compliant
N/A = not applicable	

**Electromagnetic compatibility (EMC)
Interference immunity measurements on the cover**

Immunity to electrostatic discharge IEC 61000-4-2:2008 ± 8 kV contact ± 2 kV, ± 4 kV, ± 8 kV, ± 15 kV air	Compliant
Immunity to high-frequency electromagnetic fields IEC 61000-4-3:2006+A1:2007+A2:2010 3 V/m 80 MHz–2.7 GHz 80% AM at 1 kHz	Compliant
Immunity to near fields of wireless HF communication devices IEC 61000-4-3:2006+A1:2007+A2:2010 Refer to the table with immunity to interference levels for near fields of wireless HF communication devices.	Compliant
Immunity to power frequency magnetic fields IEC 61000-4-8:2009 30 A/m 30 Hz or 60 Hz	Compliant

Immunity to interference table, near fields of wireless HF communication devices		
Radio service	Frequency band MHz	Test level V/m
TETRA 400	380 - 390	27
GMRS 460 FRS 460	430 - 470	28

Immunity to interference table, near fields of wireless HF communication devices

Radio service	Frequency band MHz	Test level V/m
LTE band 13, 17	704 - 787	9
GSM 800/900 TETRA 800 iDEN 820 CDMA 850 LTE band 5	800 - 960	28
GSM 1800 CDMA 1900 GSM 1900 DECT LTE band 1, 3, 4, 25 UMTS	1700 - 1990	28
Bluetooth WLAN 802.11 b/g/n RFID 2450 LTE band 7	2400 - 2570	28
WLAN 802.11 a/n	5100 - 5800	9

EN 4.1 Type plate

The type plates are located on the side of the fluid collector.

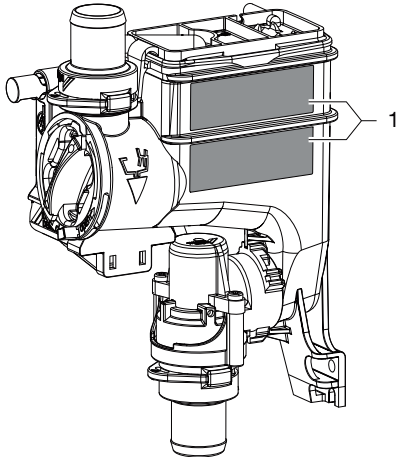

1 Type plate

4.2 Evaluation of conformity

This device has been subjected to conformity acceptance testing in accordance with the current relevant European Union guidelines. This equipment conforms to all relevant requirements.

5 Operation

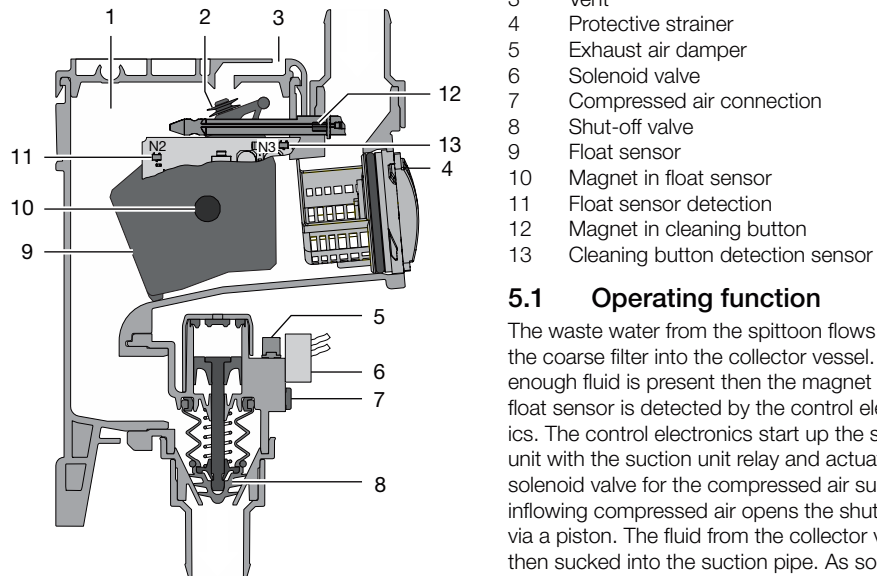

Fig. 1: Idle phase

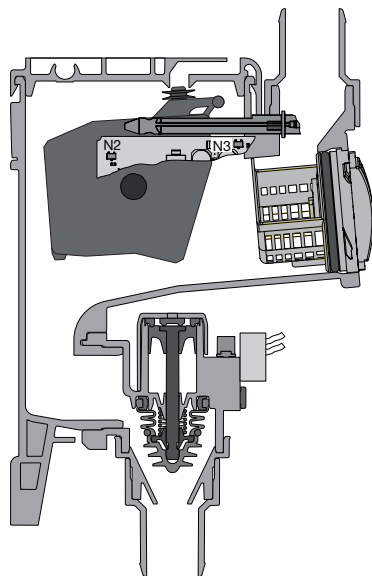

Fig. 2: Operational phase

- 1 Fluid collector

- 2 Air extraction seal
 3 Vent
 4 Protective strainer
 5 Exhaust air damper
 6 Solenoid valve
 7 Compressed air connection
 8 Shut-off valve
 9 Float sensor
 10 Magnet in float sensor
 11 Float sensor detection
 12 Magnet in cleaning button
 13 Cleaning button detection sensor

5.1 Operating function

The waste water from the spittoon flows through the coarse filter into the collector vessel. If enough fluid is present then the magnet in the float sensor is detected by the control electronics. The control electronics start up the suction unit with the suction unit relay and actuate the solenoid valve for the compressed air supply. The inflowing compressed air opens the shut-off valve via a piston. The fluid from the collector vessel is then sucked into the suction pipe. As soon as the fill level in the collector vessel has dropped, this is detected by the control electronics and the solenoid valve is switched off. While waste water continues to flow in from the spittoon the collector vessel refills and the process starts again from the beginning.

5.2 Cleaning function

The cleaning function is activated by permanent pressure on the yellow cleaning button on the spittoon valve or on the cleaning button on the switch control panel (if present). As a result the solenoid valve for the compressed air supply, and therefore the shut-off valve, is opened and the suction unit relay is actuated in order to start up the suction unit.

The cleaning and disinfection solutions can now be aspirated without hindrance through the spittoon valve into the suction pipe and into the suction unit. A suction noise can be heard at the spittoon.



6 Requirements

6.1 Setup options

- › Installation in treatment units in dental surgeries or dental clinics.

6.2 Preparing for the installation

Prior to installation of the spittoon valve the following media should be checked and if necessary adjusted; refer also to "4 Technical data":

- › Vacuum of the suction system
- › Compressed air supply
- › Water amount from the spittoon



Do not remove the gold collector or the coarse sieves from the spittoon.

6.3 Hose materials

For waste connections and suction lines only use the following hose types:

- › Flexible spiral hoses made of PVC with integrated spiral or equivalent hoses
- › Hoses that are resistant to dental disinfectants and chemicals



Plastic hoses will display signs of ageing over time. Therefore, they should be inspected regularly and replaced as necessary.

The following types of hoses must not be used:

- › Rubber hoses
- › Hoses made completely of PVC
- › Hoses that are not sufficiently flexible

6.4 Information about electrical connections

- › The supply voltage to the device must satisfy the requirements for two means of patient protection (MOPP) as set out in IEC 60601-1 in relation to the supply network.
- › The supply voltage must satisfy the following voltage/power requirements:
24 V AC/DC, 50/60 Hz, min. 2.4 VA

7 Installation

7.1 Installation overview

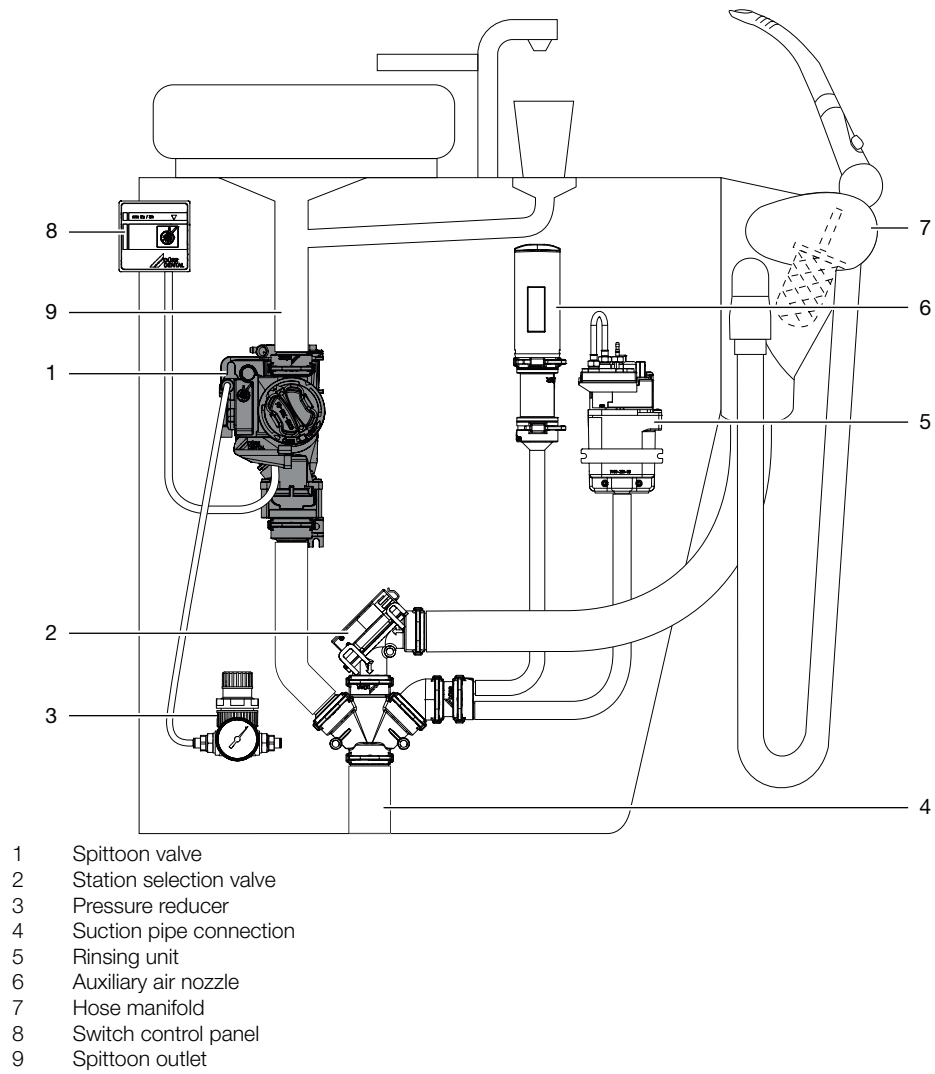

EN 7.2 Installation of the spittoon valve

i The cleaning function can be activated via the yellow button. For this reason the spittoon valve should be positioned in an easily accessible location. If this is not possible, a separate switch control panel can be used as an optional accessory.

- › Disconnect the treatment unit from the power supply and secure it so that it cannot be switched back on again.
- › Firmly screw the spittoon valve onto a suitable place on the treatment unit.
- › Connect the drain hose from the spittoon to the inlet of the spittoon valve.
- › Connect the outlet of the spittoon valve to the suction pipe.

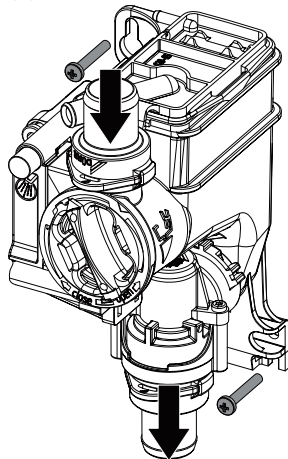

7.3 Establishing the compressed air connection

- › Disconnect a suitable compressed air line from the treatment unit.
- › Install a T-piece with 4 mm branch in the compressed air line.
- › Connect a compressed air hose to the T-piece.

- › Route the compressed air hose to the spittoon valve, cut it off straight and insert it.

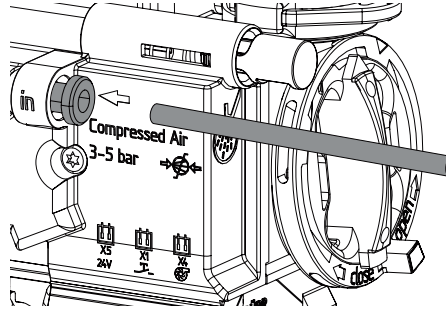

i To pull off the compressed air hose from the spittoon valve, press the black sleeve on the compressed air connection inwards.

7.4 Electrical connections

⚡ Prior to working on the unit or in case of danger, disconnect it from the mains.

i The requirements of IEC 60601-1 must be satisfied during installation.

- › Open the cover of the control electronics.
- › Route the power supply and control line to the spittoon valve.
- › Attach the connector to the connection lines.
- › Plug in the connector at the corresponding positions on the control electronics.

› Secure the connection lines with cable ties to the housing.

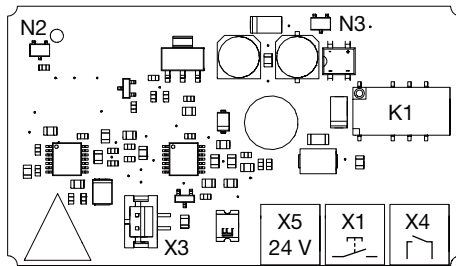
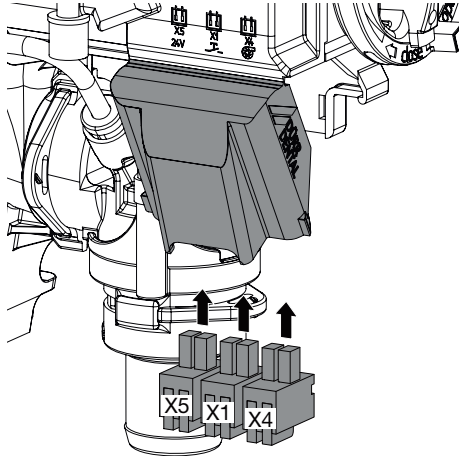

- X1 Cleaning button for switch control panel
- X3 Solenoid valve
- X4 Control line for suction unit
- X5 Power supply
- K1 Suction unit relay
- N2 Float sensor detection
- N3 Cleaning button detection sensor

EN 7.5 Circuit diagram

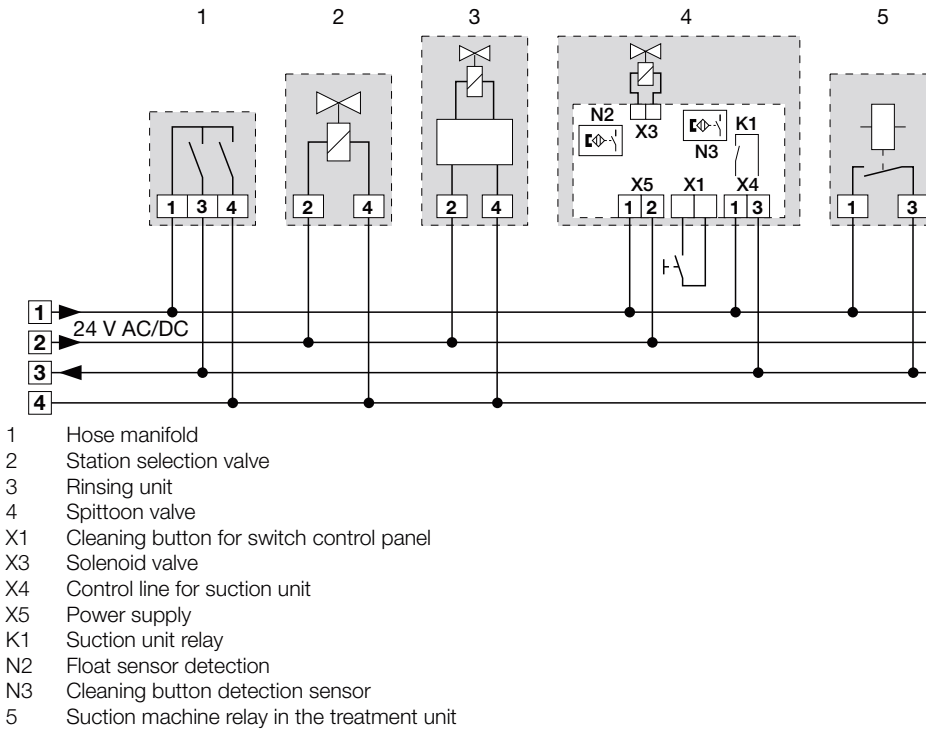

8 Commissioning

- › Turn on the unit power switch or the main surgery switch.
- › Carry out a function check of the system.
- › Check all connections for leak tightness.
- › Carry out an electrical safety check in accordance with applicable regulations (e.g. regulations concerning set up, operation and application of medical devices) and record the results as appropriate, e.g. in the technical log book.

9 Disinfection and cleaning



NOTICE

Device malfunctions or damage due to use of incorrect media

Guarantee claims may become invalid as a result.

- › Do not use any foaming agents such as household cleaning agents or instrument disinfectants.
- › Do not use abrasive cleaners.
- › Do not use agents containing chlorine.
- › Do not use any solvents like acetone.

Dürr Dental recommends

- › For disinfection and cleaning:
 - Orotol plus or Orotol ultra
- › For cleaning:
 - MD 555 cleaner

Only these products have been tested by Dürr Dental.

When using prophylaxis powders, Dürr Dental recommends the water-soluble Lunos prophylaxis powders in order to protect the Dürr Dental suction systems.

9.1 Spittoon valve

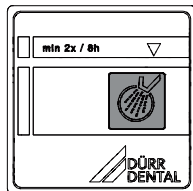
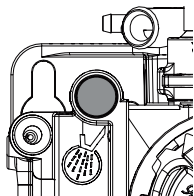

- › Switch on the rinsing for the spittoon.
- › Keep pressing the yellow cleaning button of the spittoon valve or the cleaning button on the switch control panel (if present) until rinsing of the spittoon is finished.
- › Pour disinfection solution into the spittoon and at the same time press the yellow cleaning button of the spittoon valve or the cleaning button on the switch control panel (if present) until the disinfection solution has been aspirated.

9.2 Suction system

After every treatment

- › Aspirate a glass of cold water through the large and the small suction hoses. Do this even if only the small suction hose was actually used during treatment.



Suction through the large suction hose causes a large amount of air to be drawn up, thereby considerably increasing the cleaning effect.

Daily after the end of treatment



After higher workloads before the midday break and in the evening

The following are required for disinfection/cleaning:

- ✓ Non-foaming disinfectant/cleaning agent that is compatible with the materials.
- ✓ Unit care system, e.g. OroCup
- › To pre-clean, suck up 2 litres of water with the care system.
- › Aspirate the disinfection/cleaning agent with the care system.

Once or twice a week before the midday break



Under harsher conditions (e.g. hard water or frequent use of prophylaxis powders) 1x daily before the midday break

The following are required for cleaning:

- ✓ Special non-foaming detergent for suction units that is compatible with the materials.
- ✓ Unit care system, e.g. OroCup
- › To pre-clean, suck up 2 litres of water with the care system.
- › Aspirate the cleaning agent with the care system.
- › Rinse with ca. 2 l water after the application time.

10 Maintenance



All maintenance work must be performed by a qualified expert or by one of our Service Technicians.



WARNING

Infection due to contaminated unit

- › Clean and disinfect the suction before working on the unit.
- › Wear protective equipment when working (e. g. impermeable gloves, protective goggles and mouth and nose protection).



Prior to working on the unit or in case of danger, disconnect it from the mains.

Maintenance interval	Maintenance work
Monthly	<ul style="list-style-type: none">› Press the yellow cleaning button to empty the collection vessel.› Clean the yellow coarse filter or replace it if required.
Annually	<ul style="list-style-type: none">› Check compressed air supply. *› Perform a functional test.
Every 3 years	<ul style="list-style-type: none">› Clean the float monitor in the collection vessel. *› Clean the seal on the float sensor for ventilation and replace if required. *

* Only to be performed by service technicians.

11 Tips for operators and service technicians



Any repairs exceeding routine maintenance may only be carried out by qualified personnel or our service.



WARNING

Infection due to contaminated unit

- › Clean and disinfect the suction before working on the unit.
- › Wear protective equipment when working (e. g. impermeable gloves, protective goggles and mouth and nose protection).



Prior to working on the unit or in case of danger, disconnect it from the mains.

Error	Possible cause	Remedy
Spittoon valve not working	No power supply	› Check power supply and restore. *
	Faulty connections	› Check the plug connections. *
	Relay not switching	› Check the switching function of the relay. *
	No compressed air present	› Check the compressed air supply of the spittoon valve. *
	Sensor defective	› Check the function of the sensor with the aid of the button. › Check the function by manually moving the float sensor.
Suction unit does not start up or runs continuously	Float sensor does not move in its housing	› Clean the housing and float sensor. * › Insert the float sensor correctly. *
Fluid does not drain off	Drain blocked	› Clean the drain line. * › Check whether the filter is blocked, clean if necessary.

* Only to be done by service technicians.

12 Transporting the unit



WARNING

Infection due to contaminated unit

- › Disinfect the unit before transport.
- › Close all media connections.



Wear protective equipment to avoid any risk of infection (e.g. liquid-tight protective gloves, protective goggles, face mask).

- › Before disassembly, clean and disinfect the suction unit and the unit using a suitable disinfectant approved by Dürr Dental.
- › Disinfect a defective unit using a suitable surface disinfection agent.
- › Seal all connections with sealing caps.
- › Pack the unit securely in preparation for transport.

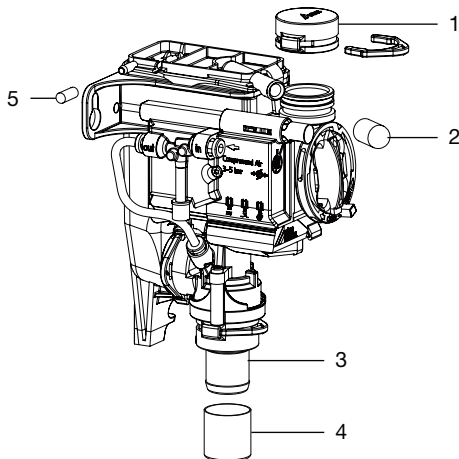

- 1 DürrConnect dummy bushing (order no. 0700-700-10E)
- 2 Protective cap (order no. 9000-412-85)
- 3 DürrConnect hose connector socket Ø 20 mm (order no. 0700-700-20E)
- 4 Protective cap (order no. 9000-412-98)
- 5 Sealing cap (order no. 9000-310-002)



Hersteller / Manufacturer:

DÜRR DENTAL SE
Höpfigheimer Str. 17
74321 Bietigheim-Bissingen
Germany
Fon: +49 7142 705-0
www.duerrdental.com
info@duerrdental.com



CAS 1 Combi-Separator

EN

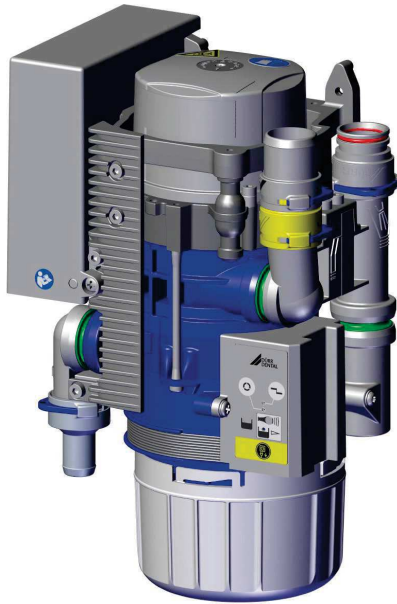

Installation and operating instructions

CE

7117100018L30



 **DÜRR
DENTAL**

2011V003

Contents



Important information

1 About this document	3
1.1 Warnings and symbols	3
1.2 Copyright information	4
2 Safety	4
2.1 Intended purpose	4
2.2 Intended use	4
2.3 Improper use	4
2.4 Systems, connection with other devices	5
2.5 General safety information	5
2.6 Specialist personnel	5
2.7 Notification requirement of serious incidents	5
2.8 Electrical safety	5
2.9 Only use original parts	6
2.10 Transport	6
2.11 Disposal	6



Product description

3 Overview	7
3.1 Scope of delivery	7
3.2 Accessories	7
3.3 Optional items	7
3.4 Consumables	7
3.5 Wear parts and replacement parts	7
4 Technical data	8
4.1 CAS 1 Combi-Separator	8
4.2 Type plate	12
4.3 Evaluation of conformity	12
4.4 Approvals	12
5 Operation	13
5.1 Operation	14
5.2 Separation	14
5.3 Spillover connections	14
5.4 Station selection valve / safety valve	14

5.5 Amalgam separation	14
5.6 Sediment level measurement	15
5.7 Operating problems	15
5.8 Service key	15

EN



Assembly

6 Requirements	16
6.1 Installation/setup room	16
6.2 Setup options	16
6.3 Hose materials	16
6.4 Installation and routing of hoses and pipes	16
6.5 Information about electrical connections	16
6.6 Information about connecting cables	16
7 Installation	17
7.1 Combining devices safely	17
7.2 Installation of the CAS 1 in treatment units	17
7.3 Electrical connections, controller	18
7.4 Electrical connections	19
8 Commissioning	20
9 Service program	21
10 Description of the service program	22
10.1 Service program ON/OFF	22
10.2 Display test	22
10.3 Sediment level measurement	22
10.4 Motor start - motor braking	22
10.5 Input and output signals	22



Usage

11 Display/handling	23
11.1 Ready for operation	23
11.2 Amalgam collector vessel is 95% full	23
11.3 Amalgam collector vessel is 100% full	23

Contents

EN

11.4	Amalgam collector vessel not in position	23
11.5	Motor fault	23
12	Disinfection and cleaning	24
12.1	After every treatment	24
12.2	Daily after the end of treatment	24
12.3	Once or twice a week before the midday break	25
13	Replace the amalgam collector vessel	25
13.1	Disposal of the collector vessel	25
14	Maintenance	27
14.1	Tests	28



Troubleshooting

15	Tips for operators and service technicians	29
16	Transporting the unit	32
16.1	Close CAS 1	32



Appendix

17	Handover record	33
-----------	----------------------------------	-----------

 Important information

1 About this document

These installation and operating instructions represent part of the unit.

 If the instructions and information in these installation and operating instructions are not followed, Dürr Dental will not be able to offer any warranty or assume any liability for the safe operation and the safe functioning of the unit.

The German version of the installation and operating instructions is the original manual. All other languages are translation of the original manual. These installation and operating instructions apply to:

CAS 1

REF: 7117-100-51

1.1 Warnings and symbols

Warnings

The warnings in this document are intended to draw your attention to possible injury to persons or damage to machinery.

The following warning symbols are used:

 General warning symbol

 Biohazard warning

The warnings are structured as follows:

 **SIGNAL WORD**
Description of the type and source of danger

Here you will find the possible consequences of ignoring the warning

› Follow these measures to avoid the danger.

The signal word differentiates between four levels of danger:

- **DANGER**
Immediate danger of severe injury or death
- **WARNING**
Possible danger of severe injury or death
- **CAUTION**
Risk of minor injuries
- **NOTICE**
Risk of extensive material/property damage

EN

Other symbols

These symbols are used in the document and on or in the unit:

 Note, e.g. specific instructions regarding efficient and cost-effective use of the unit.

 Refer to Operating Instructions.

 Wear protective gloves.

 Disconnect all power from the unit.

 Hose manifold connection

 Spittoon connections

 Suction unit connection

 Drain connection

 Unit in operation

 Unit operation interrupted





 Audible signal/melody sounds

 Do not reuse

 CE labelling

 Important information

EN

-  Order number
-  Serial number
-  Medical device
-  Health Industry Bar Code (HIBC)
-  Manufacturer

1.2 Copyright information

All circuits, processes, names, software programs and units mentioned in this document are protected by copyright.

The Installation and Operating Instructions must not be copied or reprinted, neither in full nor in part, without written authorisation from Dürr Dental.

2 Safety

Dürr Dental has designed and constructed this unit so that when used properly and for the intended purpose it does not pose any danger to people or property.

Despite this, the following residual risks can remain:

- Personal injury due to incorrect use/misuse
- Personal injury due to mechanical effects
- Personal injury due to electric shock
- Personal injury due to radiation
- Personal injury due to fire
- Personal injury due to thermal effects on skin
- Personal injury due to lack of hygiene, e.g. infection

2.1 Intended purpose

The CAS 1 Combi-Separator is designed for continuous separation of liquids and air and for separation of amalgam from the entire waste water from dental treatment units.

2.2 Intended use

The Combi-Separator is designed for installation in the suction line of a dry suction system after the hose manifold and spittoon.

Service, maintenance, recurring tests and cleaning must be performed in accordance with the manufacturer's information.

The permissible flow rate must be observed.

A rinsing unit is required for surgical procedures and for procedures using prophylaxis powders.

The disposable amalgam containers must only be used once.

2.3 Improper use

Any use of this appliance / these appliances above and beyond that described in the Installation and Operating Instructions is deemed to be incorrect usage. The manufacturer cannot be held liable for any damage resulting from incorrect usage. The operator will be held liable and bears all risks.

This includes:

- Use for separation of dust, sludge, plaster or similar.
- Use in conjunction with flammable or explosive mixtures.
- Installation in a manner that does not comply with the installation instructions, in particular installation in rooms containing a potentially explosive atmosphere.
- Cleaning and disinfection with agents containing sodium hypochlorite or potassium hypochlorite.

2.4 Systems, connection with other devices

Additional devices connected with medical electrical devices must be proven to conform with their corresponding IEC or ISO standards. All configurations must continue to comply with the standard requirements for medical systems (see IEC 60601-1).

Whoever connects additional devices to medical electrical devices automatically becomes the system configurator and is responsible for ensuring that the system corresponds with the standard requirements for systems. Local laws take priority over the requirements outlined above.

2.5 General safety information

- › Always comply with the specifications of all guidelines, laws, and other rules and regulations applicable at the site of operation for the operation of this unit.
- › Check the function and condition of the unit prior to every use.
- › Do not convert or modify the unit.
- › Comply with the specifications of the Installation and Operating Instructions.
- › The Installation and Operating Instructions must be accessible to all operators of the unit at all times.

2.6 Specialist personnel

Operation

Unit operating personnel must ensure safe and correct handling based on their training and knowledge.

- › Instruct or have every user instructed in handling the unit.

Installation and repairs

- › Installation, readjustments, alterations, upgrades and repairs must be carried out by Dürr Dental or by qualified personnel specifically approved and authorized by Dürr Dental.

2.7 Notification requirement of serious incidents

The operator/patient is required to report any serious incident that occurs in connection with the device to the manufacturer and to the competent authority of the Member State in which the operator and/or patient is established/resident.

2.8 Electrical safety

- › Comply with all the relevant electrical safety regulations when working on the unit.
- › Never touch the patient and unshielded plug connections on the device at the same time.
- › Replace any damaged cables or plugs immediately.

Observe the EMC rules concerning medical devices

- › The unit is intended for use in professional healthcare facilities (in accordance with IEC 60601-1-2). If the appliance is operated in another environment, potential effects on electromagnetic compatibility must be taken into account.
- › Do not operate the unit in the vicinity of HF surgical instruments or MRT equipment.
- › Keep a minimum distance of 30 cm between the unit and mobile radio devices.
- › Note that cable lengths and cable extensions have effects on electromagnetic compatibility.



NOTICE

Negative effects on the EMC due to non-authorised accessories

- › Use only Dürr Dental parts or accessories specifically approved by Dürr Dental.
- › Using any other accessories may result in increased electromagnetic interference emissions or the unit having reduced electromagnetic immunity, leading to an erroneous operation mode.



NOTICE

Erroneous operation mode due to use immediately adjacent to other devices or with other stacked devices

- › Do not stack the unit together with other devices.
- › If this is unavoidable, the unit and other devices should be monitored in order to ensure that they are working correctly.

- › Untaminated parts (e.g. electronics, plastic and metal parts etc.) should be disposed of in accordance with the local waste disposal regulations.
- › If you have any questions about the correct disposal of parts, please contact your dental trade supplier.



An overview of the waste keys for Dürr Dental products can be found in the download area at www.duerdental.com (document no. P007100155).

2.9 Only use original parts

- › Only use accessories and optional items that have been recommended or specifically approved by Dürr Dental.
- › Only use only original wear parts and replacement parts.



DÜRR MEDICAL accepts no liability for damages or injury resulting from the use of non-approved accessories or optional accessories, or from the use of non-original wear parts or replacement parts.

The use of non-approved accessories, optional accessories or non-genuine wear parts / replacement parts (e.g. mains cables) can have a negative effect in terms of electrical safety and EMC.

2.10 Transport

The original packaging provides optimum protection for the unit during transport.

If required, original packaging for the unit can be ordered from Dürr Dental.



Dürr Dental will not accept any responsibility or liability for damage occurring during transport due to the use of incorrect packaging, even where the unit is still under guarantee.

- › Only transport the unit in its original packaging.
- › Keep the packing materials out of the reach of children.

2.11 Disposal



The unit may be contaminated. Instruct the company disposing of the waste to take the relevant safety precautions.

- › Decontaminate potentially contaminated parts before disposing of them.

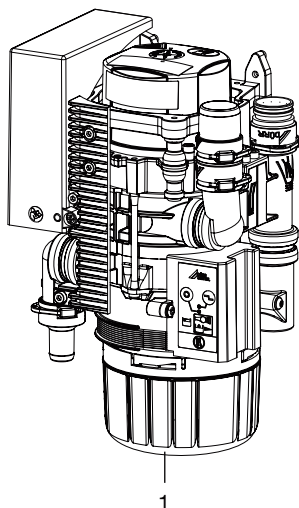
 **Product description****3 Overview**

1 CAS 1 Combi-Separator

3.1 Scope of delivery

 The scope of delivery can vary slightly depending on the version.

The following items are included in the scope of delivery:

CAS 1 **7117-100-51**

- Combi-Separator
- Replacement disposable amalgam container
- Installation and operating instructions
- Operating Handbook

3.2 Accessories

The following items are required for operation of the device, depending on the application:

Disposable amalgam container . . . 7117-033-00

3.3 Optional items

The following optional items can be used with the device:

Various installation sets are available on request.

Display panel 7805-116-00E

Cable for display panel, 1 m 9000-119-043

Cable for display panel, 3 m 9000-119-042

Station selection valve	7560-500-60
Station selection valve for CAS 1 /	
CS 1	7560-500-80
Vario rinsing unit	7100-260-50
OroCup care system	0780-350-00
Test vessel	7117-064-00
Rinsing unit II	7100-250-50
Safety transformer 24 V, 100 VA . .	9000-150-46
Housing	7117-800-51

EN

3.4 Consumables

The following materials are consumed during operation of the device and must be ordered separately:

Disposable amalgam container . . . 7117-033-00

DürrConnect protective strainer,
5 pieces 0700-700-18E

DürrConnect protective strainer,
5 pieces 0700-700-28E

Orotol plus (2.5 litre bottle) CDS110P6150

MD 550 spittoon bowl cleaner
(750 ml bottle) CCS550C4500

MD 555 cleaner (2.5 litre bottle) . . CCS555C6150

3.5 Wear parts and replacement parts

The following working parts need to be changed at regular intervals (refer to the "Maintenance" section):

Bellows 7117-420-25E

Service kit (3-year interval) 7117-980-32

Service kit (5-year interval) 7117-980-30

 Information about replacement parts is available from the portal for authorised specialist dealers at:
www.duerrdental.net.

4 Technical data

4.1 CAS 1 Combi-Separator

EN

Electrical data – centrifuge motor		
Rated voltage	V	24 AC
Frequency	Hz	50 / 60
Rated power	VA	100
Current consumption in stand-by	mA	200
Signal input from hose manifold	V	24 AC
	Hz	50/60
Signal output	V	24 DC
	mA	300
Media		
Air flow volume	l/min	≤ 350
Flow rate		high
The suction system must be suitable for a high flow rate in accordance with EN ISO 10637.		
Max. pressure	hPa/mbar	-160
Min. volume of aspiration fluid	l/min	≥ 0.1
max.	l/min	≤ 1.0
Water supply, spittoon	l/min	≤ 3
Total flow of waste liquids	l/min	≤ 4
Usable volume in amalgam collecting container	ccm	approx. 90
Replacement interval		4 - 6 months
General data		
Drive motor nominal speed	rpm	2800
Operating mode		S5 95% duty cycle*
Type of protection		IP 20
Protection class		II
Noise level ** approx.	dB(A)	55
Dimensions (H x W x D)	mm	255 x 157 x 110
Weight, approx.	kg	2.7
Separation rate	%	≥ 95
* DC = duty cycle		
** Noise level in accordance with EN ISO 3746		
Ambient conditions during storage and transport		
Temperature	°C	-10 to +60
Relative humidity	%	< 95

Ambient conditions during operation

Temperature	°C	+10 to +40
Relative humidity	%	< 70

Classification

Medical Device Class	I
----------------------	---

EN

Electromagnetic compatibility (EMC)**Interference emission measurements**

High-frequency emissions in accordance with CISPR 11	Group 1 Class B
Interference voltage at the power supply connection CISPR 11:2009+A1:2010	Compliant
Electromagnetic interference radiation CISPR 11:2009+A1:2010	Compliant
Emission of harmonics IEC 61000-3-2:2005+A1:2008+A2:2009	Compliant
Voltage changes, voltage fluctuations and flicker emissions IEC 61000-3-3:2013	Compliant

Electromagnetic compatibility (EMC)**Interference immunity measurements**

Immunity to electrostatic discharge IEC 61000-4-2:2008	Compliant
Immunity to high-frequency electromagnetic fields IEC 61000-4-3:2006+A1:2007+A2:2010	Compliant
Immunity to near fields of wireless HF communication devices IEC 61000-4-3:2006+A1:2007+A2:2010	Compliant
Immunity to fast electrical transients/bursts – AC mains voltage IEC 61000-4-4:2012	Compliant
Immunity to electrical fast transients/bursts – I/O, SIP/SOP ports IEC 61000-4-4:2012	Compliant
Immunity to interference, surges IEC 61000-4-5:2005	Compliant
Immunity to conducted disturbances, induced by radio-frequency fields – AC mains voltage IEC 61000-4-6:2013	Compliant
Immunity to conducted disturbances, induced by radio-frequency fields – SIP/SOP ports IEC 61000-4-6:2013	Compliant
Immunity to power frequency magnetic fields IEC 61000-4-8:2009	Compliant

EN

**Electromagnetic compatibility (EMC)
Interference immunity measurements**

Immunity to voltage dips, short interruptions and voltage variations
IEC 61000-4-11:2004

Compliant

Immunity to interference levels, near fields of wireless HF communication devices

Radio service	Frequency band MHz	Test level V/m
TETRA 400	380 - 390	27
GMRS 460 FRS 460	430 - 470	28
LTE band 13, 17	704 - 787	9
GSM 800/900 TETRA 800 iDEN 820 CDMA 850 LTE band 5	800 - 960	28
GSM 1800 CDMA 1900 GSM 1900 DECT LTE band 1, 3, 4, 25 UMTS	1700 - 1990	28
Bluetooth WLAN 802.11 b/g/n RFID 2450 LTE band 7	2400 - 2570	28
WLAN 802.11 a/n	5100 - 5800	9

**Electromagnetic compatibility (EMC)
Interference immunity measurements on the supply input**

Immunity to fast electrical transients/bursts – AC mains voltage
IEC 61000-4-4:2012
± 2 kV
100 kHz repetition rate

Compliant

Immunity to surges, line-to-line
IEC 61000-4-5:2005
± 0.5 kV, ± 1 kV

Compliant

Immunity to surges, line-earth
IEC 61000-4-5:2005
± 0.5 kV, ± 1 kV, ± 2 kV

N/A

Electromagnetic compatibility (EMC)		EN
Interference immunity measurements on the supply input		
Immunity to conducted disturbances, induced by radio-frequency fields – AC mains voltage IEC 61000-4-6:2013 3 V 0.15–80 MHz	Compliant	
ISM frequency bands 0.15–80 MHz 80% AM at 1 kHz		
Immunity to voltage dips, short interruptions and voltage variations IEC 61000-4-11:2004	Compliant	
N/A = not applicable		
Electromagnetic compatibility (EMC)		EN
Interference immunity measurements SIP/SOP		
Immunity to electrostatic discharge IEC 61000-4-2:2008 ± 8 kV contact ± 2kV, ± 4 kV, ± 8 kV, ± 15 kV air	Compliant	
Immunity to electrical fast transients/bursts – I/O, SIP/SOP ports IEC 61000-4-4:2012 ± 1 kV 100 kHz repetition rate	Compliant	
Immunity to impulse voltages, conductor to earth IEC 61000-4-5:2005 ± 2 kV	N/A	
Immunity to conducted disturbances, induced by radio-frequency fields – SIP/SOP ports IEC 61000-4-6:2013 3 V 0.15–80 MHz	Compliant	
ISM frequency bands 0.15–80 MHz 80% AM at 1 kHz		
N/A = not applicable		

4.2 Type plate

The type plates are located on the cover of the motor.

EN

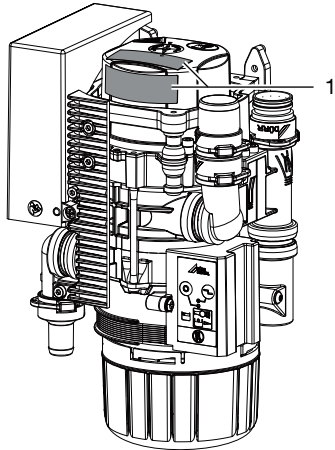

1 Type plate

4.3 Evaluation of conformity

This device has been subjected to conformity acceptance testing in accordance with the current relevant European Union guidelines. This equipment conforms to all relevant requirements.

4.4 Approvals

**Centre of Competence in Civil Engineering,
Berlin**

Test number Z-64.1-20

Separation method compliant with standard

ISO 11143 Type 1

5 Operation

EN

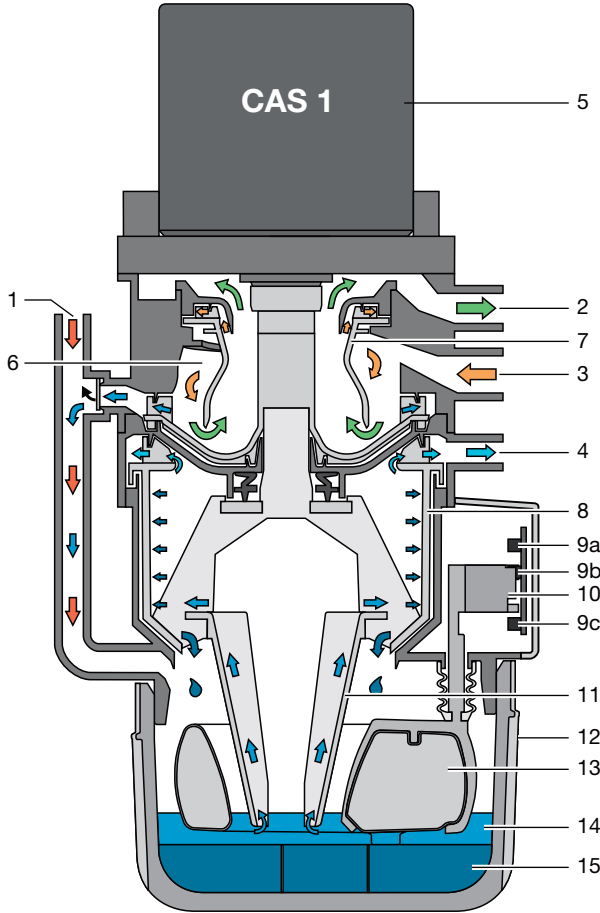

- 1 Fluid intake
- 2 Vacuum, to suction unit
- 3 Aspiration input
- 4 Fluid output
- 5 Motor
- 6 Separation
- 7 Separation rotor
- 8 Centrifuge
- 9 Light barriers (3x)
- 10 Sensor enclosure
- 11 Cone pump
- 12 Amalgam collector vessel
- 13 Float sensor
- 14 Fluids
- 15 Amalgam particles

5.1 Operation

CAS 1 Combi-Separator

EN

The task of the CAS 1 combi-separator is to provide continuous separation of secretions and air as well as the amalgam separation of all the waste water from the treatment unit.

The waste water flows through the connection (1) from the spittoon directly into the centrifuge (8) and amalgam separation.

During the suction phase the aspirated secretions are separated from the aspirated air in the separation unit (6). The secretions accumulating in the separation unit are continuously transported to the centrifuge (8), where the amalgam particles are then separated.

Underneath the centrifuge is a replaceable amalgam collector vessel (12), into which the separated amalgam particles (15) are rinsed once the centrifuge (8) is switched off. A float sensor (13) checks the level within the collector vessel and sends a signal to the display panel when it needs replacing. In combination with a light barrier (9c), this float sensor also monitors whether a collector vessel is in use.

The compact size of the CAS 1 Combi-Separator allows it to be installed in dental treatment units. This results in short secretion carrying lines. After the centrifuge is switched off, the braking cycle triggers a self-cleaning process. This self-cleaning process also leads to smooth and silent running, as well as providing a separation efficiency of more than 95%, even under heaviest loads.

5.2 Separation

At the inlet connection (3) of the CAS 1, the aspirated fluid/air mix is accelerated and set into a spiral motion in the separation unit (6). The resulting centrifugal forces sling the aspirated particles against the outer wall. The air is continuously separated from the fluid and escapes via the spinning separation rotor (7) to the suction unit. The aspirated air is subject to high centrifugal forces by the separation rotor (7), which is driven by the motor (1), which ensures that no fluid or blood foam can be carried into the suction unit. The spiral motion feeds the separated fluid continuously to the pump wheel, which transports the fluid into the collector vessel. The fluid is transported to the centrifuge (8) via a pump cone (11).

An external station selection valve connects the CAS 1 with the suction unit via the vacuum connection (2).

5.3 Spittoon connections

The waste water from the spittoon flows through a protective strainer on the fluid inlet (1) and into the collector vessel (12). Once sufficient fluid has been collected, the float sensor (13) activates a light barrier (9a) and (9b) via a sensor housing (10) and switches on the motor (1). The fluid is transported to the centrifuge (8) via a pump cone (11).

5.4 Station selection valve / safety valve

The station selection valve has 2 tasks:

1st task:

The station selection valve interrupts the suction flow between the hose manifold and the suction unit. As soon as a suction hose is removed from the hose manifold, a solenoid valve opens the station selection valve and suction flow is enabled.

2nd task:

The station selection valve also acts as a safety valve. If the CAS 1 is over-full or not functioning properly, the system will perform a safety shutdown. This safety shutdown prevents fluids from being drawn into the dry suction pipe.



For single station suction systems, the station selection valve takes over the function of the safety valve.

In various types, a station selection valve is already integrated in the CAS 1. The station selection valve is on the connection (2) of the CAS 1.

5.5 Amalgam separation

The switches in the hose manifold or the light barrier of the sensor system switch on the motor and the associated centrifuge (8).

The fluid containing amalgam particles flows continuously to the collector vessel (12). The fluids ejected by the centrifuge are pumped through the fluid output (4) to the central waste water system.

As soon as no further fluid is fed to the amalgam separator, e.g. when the suction hose is placed back in the hose manifold, the centrifuge drum is switched off after a short delay time. This switch-

off brakes the motor, as a result of which the ring of water, which continues to rotate due to inertia, rinses the separated particles out of the centrifuge (8) downwards into the collector vessel. The separated amalgam particles form a sediment in the replaceable collector vessel. The level of fluid in the collector is regulated by the pump cone so that the risk of fluid escaping when the collector vessel is changed can be avoided.

5.6 Sediment level measurement

The fill level in the collector vessel (12) is checked by a float sensor (13) every time the main power switch is switched on.

The centrifuge motor starts, fluid is transported via the pump cone to the centrifuge drum (8) and provides a constant level of fluid (underside of the cone pump) in the collector vessel. The float sensor sinks. Two light barriers (9a) and (9b) measure the fluid level. Once the level reaches 95% in the collector vessel, this is displayed on the display panel.

5.7 Operating problems

If the unit is not ready for operation due to a fault, this will be indicated on the display panel via illuminated LEDs and an audible signal.

5.8 Service key

On the display panel there is a service key that can be used to switch off the audible signal in the event of a fill level warning or if a fault message is indicated. This button can also be used to start the device manually. To do this, press the button for longer than 2 seconds until the drive motor starts up.

Assembly

EN

6 Requirements

6.1 Installation/setup room

The room chosen for set up must fulfil the following requirements:

- Closed, dry, well-ventilated room
- Should not be a room made for another purpose (e. g. boiler room or wet cell)

6.2 Setup options

CAS 1 Combi-Separator

- Directly in the treatment unit.
- In a special housing in an extension of the treatment unit.

6.3 Hose materials

For waste connections and suction lines only use the following hose types:

- Flexible spiral hoses made of PVC with integrated spiral or equivalent hoses
- Hoses that are resistant to dental disinfectants and chemicals



Plastic hoses will display signs of ageing over time. Therefore, they should be inspected regularly and replaced as necessary.

The following types of hoses must not be used:

- Rubber hoses
- Hoses made completely of PVC
- Hoses that are not sufficiently flexible

6.4 Installation and routing of hoses and pipes

- › Execute the on-site pipe installation in accordance with the applicable local regulations and standards.

- › Lay the hose installation of the drains to or from the unit at a sufficient incline.



If incorrectly laid, the hoses can become blocked with sedimentation.

6.5 Information about electrical connections

- › Ensure that electrical connections to the mains power supply are carried out in accordance with current valid national and local regulations and standards governing the installation of low voltage units in medical facilities.
- › Install an all-pole disconnect switch with a contact opening width of at least 3 mm in the electrical connection to the mains power supply.
- › Observe the current consumption of the devices that are to be connected.
- › Install electrical lines without mechanical tension.
- › Make the electrical connection via the main power switch of the treatment unit or via the main power switch of the practice.

6.6 Information about connecting cables

Mains supply cable

Installation type	Line layout (minimum requirements)
Fixed installation	– Plastic sheathed cable (e.g. type NYM-J)
Flexible	– PVC flexible line (e.g. H05 VV-F) or – Rubber connection (e.g. H05 RN-F or H05 RR-F)

Control cable

Installation type	Line layout (minimum requirements)
Fixed installation	– Shielded sheathed cable (e.g. (N)YM (St)-J)

Installation type	Line layout (minimum requirements)
Flexible	<ul style="list-style-type: none"> – PVC data cable with shielded cable sheathing, as used for telecommunications and IT processing systems (e.g. type LiYCY) or <ul style="list-style-type: none"> – Lightweight PVC control cable with shielded cable sheathing

Wire cross-section

- Unit feed:
 - 0.75 mm²
- Connection external valves / units:
 - 0.5 mm²

7 Installation



Prior to working on the unit or in case of danger, disconnect it from the mains.

EN

7.1 Combining devices safely

Take care when connecting units together or to parts of other systems as there is always an element of risk (e.g. due to leakage currents).

- › Only connect units when there can be no question of danger to operator or to patient.
- › Only connect units when it is safe to do so and when there is no risk of damage or harm to the surroundings.
- › If it is not 100% clear from the unit data sheet that such connections can be safely made or if you are in any doubt, always get a suitably qualified person (e.g. the manufacturer) to verify that the setup is safe.

7.2 Installation of the CAS 1 in treatment units

The CAS 1 Combi Separator for KaVo treatment units must be set up in a defined installation setup in order to meet the relevant safety standards. For this reason it must only be installed in the treatment units that have been designed and approved for this purpose by KaVo.

KaVo-approved treatment units:

New units delivered from 01/2016 onwards: E50, E50 Life, E70/E80, E70/E80 Vision, 1058, 1058 Life

Spare parts requirements for old units such as 1078 and 1080 among others.



WARNING

Infection due to contaminated unit

- › Clean and disinfect the suction before working on the unit.
- › Wear protective equipment when working (e. g. impermeable gloves, protective goggles and mouth and nose protection).

Attach the unit vertically at a suitable position in the treatment unit. The unit is mounted on rubber pads and suspended in a metal frame. This mounting arrangement prevents the transmission of any vibrations to the treatment unit while the

device is running. Vibrations may occur if the unit is not positioned vertically. A minimum distance of 3 mm must be maintained to the surroundings.

EN

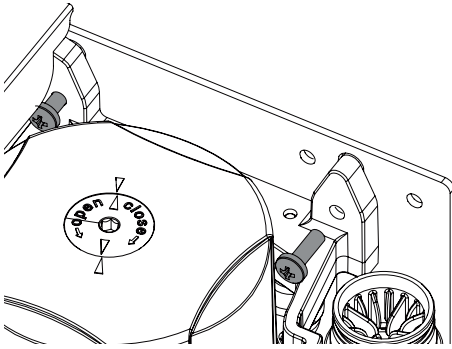

Station selection valve

In various types, the station selection valve is directly mounted on the CAS 1. The station selection valve (for separate installation) should be fitted in the suction pipe in the treatment unit, preferably near the end connection in the floor socket. In some installation setups the station selection valve also functions as a safety valve, so its actuation must be implemented via the CAS 1.

For further information, refer to the station selection valve installation and operating instructions

Inlet and outlet hoses

Connect and attach the inlet and outlet hoses with DürrConnect connectors to the relevant connections on the unit. Route the hoses at an incline.

Recommended diameter of the connection hoses: \varnothing 25 mm.

The minimum nominal width for the outlet hose is 15 mm.

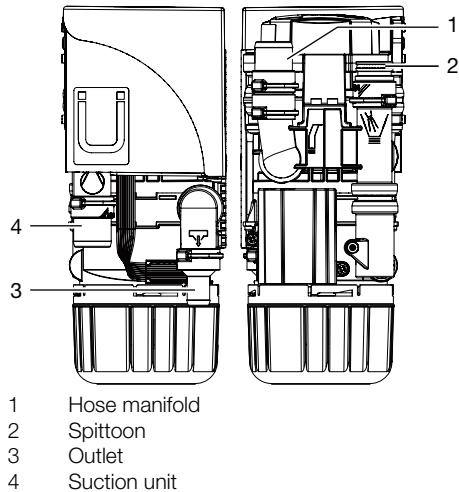

- 1 Hose manifold
- 2 Spittoon
- 3 Outlet
- 4 Suction unit

Spittoon connections

In some dental units it is possible that noises can be heard at the spittoon, which are amplified by the funnel shape of the spittoon itself. In this case, the outlet between spittoon and CAS 1 should be bled. A corresponding siphon trap with ventilation is available as a special accessory.

Rinsing unit

It is recommended that the suction system is equipped with a rinsing unit, e.g. in the treatment unit. The rinsing unit provides a small amount of water during aspiration. This dilutes the aspirated fluids (blood, saliva, rinsing water etc.), which can then be transported more effectively.

7.3 Electrical connections, controller

Power supply:

- Safety transformer order number: 9000-150-46

or

- Safety transformer 24 V AC with a with an isolator consisting of two means of patient protection (MOPP) between the mains circuit and secondary circuit, min. 100 VA, secondary fuse T 4 AH (or IEC 60127-2/V T 4 AH, 250 V)

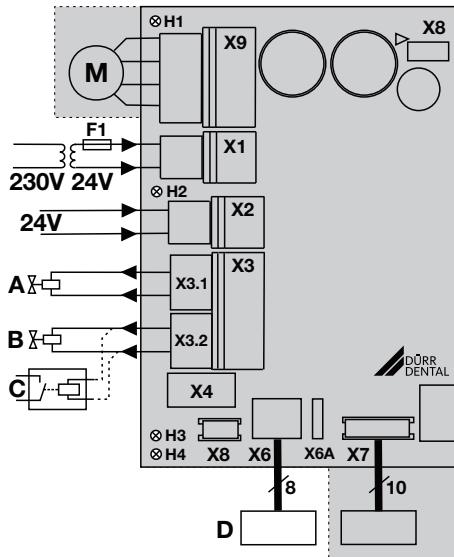

- X1 Power supply in accordance with EN 60601-1, 24 V AC
- X2 Signal input 24 V AC/DC
- X3.1 Place selection valve / safety valve (only CAS 1, max. output 8 W)
- X3.2 Rinsing unit (CAS 1 only)
- X4 CAN bus
- X6 Display panel, external (X6A = connection for predecessor model)
- X7 Sensor technology
- X8 Production interface
- X9 Motor
- H1 Motor control display
- H2 Manifold control display
- H3 Place selection valve control display
- H4 Control display, collecting container missing
- A Place selection valve
- B Rinsing unit
- C Suction unit relay (alternative)
- D Display panel, external

7.4 Electrical connections

Station selection valve / safety valve

- › Connect the station selection valve / safety valve using a 2-core wire with connector to the X3 connection of the control.

Rinsing unit

- › Connect the rinsing unit using a 2-core wire with connector to the X3 connection of the control.



At the connection for the rinsing unit, a suction unit relay, for example, can be connected if there is no isolation present between the suction unit signal and station selection valve in the treatment unit. Note the power consumption of the suction unit relay.

EN

Display panel



The display panel is used to indicate messages acoustically and visually (via LEDs).

A display panel is already integrated in the unit and should be visible/audible at all times. If the display panel is not visible/audible, fit an additional display panel in an easily visible location. The display panel is connected to the X6 socket (RJ-45 socket). An existing Dürr Dental display panel with a 6-pin connector can be connected to the X6A connector when replacing an older device.

If the installation of the amalgam separator in a neighbouring room or in the basement results in distances of more than 3 m, we recommend installing a shielded network cable with RJ-45 sockets.

8 Commissioning

EN



In many countries technical medical products and electrical devices are subject to regular checks at set intervals. The owner must be instructed accordingly.

- › Turn on the unit power switch or the main surgery switch.
- › Carry out an electrical safety check in accordance with applicable local regulations (e.g. the German Ordinance on the Installation, Operation and Use of Medical Devices / Medizinprodukte-Betreiberverordnung) and record the results as appropriate, e.g. in the technical log book.
- › Check the aspiration function.
- › Check the start function via the spittoon.
- › Check the connections, hoses and device for leaks.

9 Service program

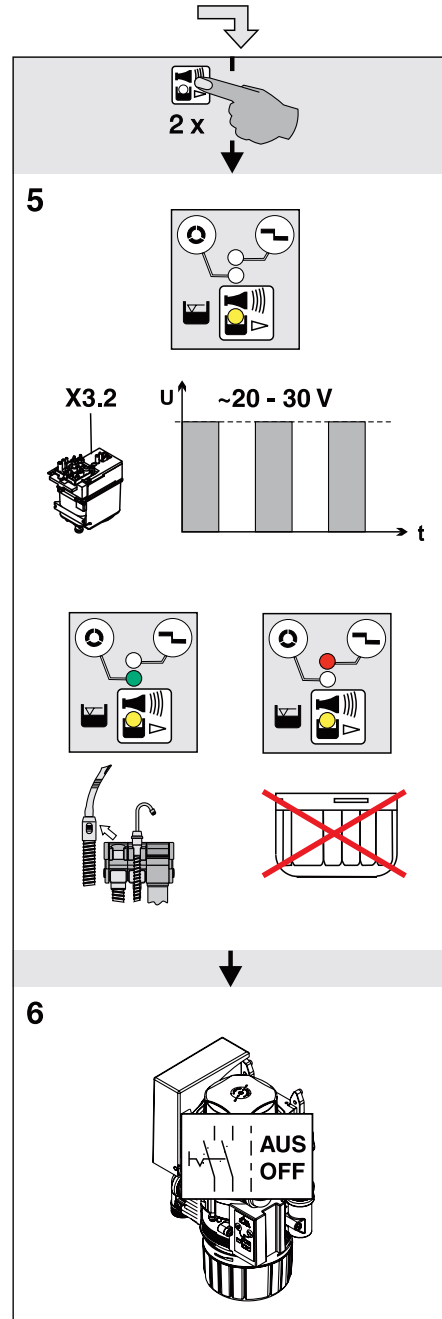
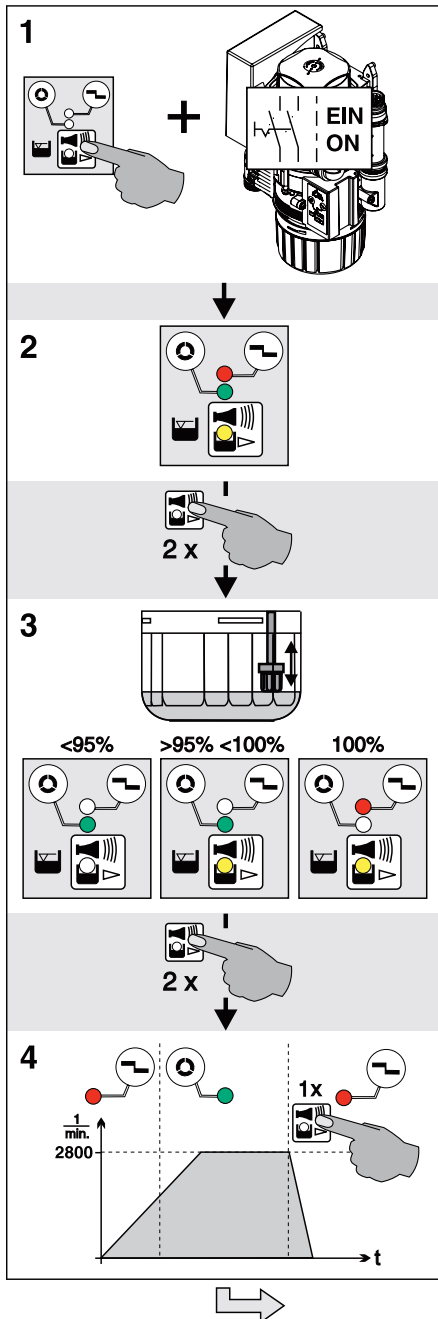

EN

10 Description of the service program

EN



Wear protective equipment to avoid any risk of infection (e.g. liquid-tight protective gloves, protective goggles, face mask).

The various unit functions can be checked with the aid of the service program.

The individual program steps are:

- Display test
- Sediment level measurement
- Motor start and motor braking with rpm check
- Input and output signals

Function of the service key:

- By pressing the service key twice the next individual program step is called up.
- By pressing the service key once that program step is repeated.

A press of the service key is confirmed by an audible signal.

10.1 Service program ON/OFF

On

- Press the service key and switch on the voltage supply to the unit.
- As soon as a signal melody can be heard, release the service key.
The green, yellow and orange LEDs on the display panel light up (display test) and the service program is activated.

Off

Switch off the main supply to the unit.

10.2 Display test

The display test is activated as soon as the service program is started.

The LEDs on the display panel are checked. All three LEDs must come on. There is also an audible signal, which can be switched off by pressing the service button.

10.3 Sediment level measurement



While the service program is activated, the safety check for the collector vessel is deactivated.

The sediment level measurement can be used to check the function of the sediment sensor and the function of the LEDs.

Every time the service key is pressed, the sediment level is checked. If a test collector vessel is used for this, the different levels can be scanned and made visible on the display panel.

While changing the collectors (collector vessel - test collector vessel) in the service program the unit remains in the ON state.

10.4 Motor start - motor braking

The drive motor starts and, after approx. 5 seconds, braking is applied. If the service key is pressed during these 5 seconds, the motor will immediately be braked.

This procedure can be repeated by pressing the service key 1x again.

The drive motor starts up.

As a result of the rpm monitoring, the LED will change from orange to green upon start-up and from green to orange upon braking.

10.5 Input and output signals

- After this program item is activated, the yellow LED flashes and a cycled DC voltage (approx. 22-30 V) can be measured at the terminal for the rinsing unit.
- If the suction hose is lifted off the hose manifold the green LED will also come on.
- Removal of the collecting container causes the red LED to illuminate.

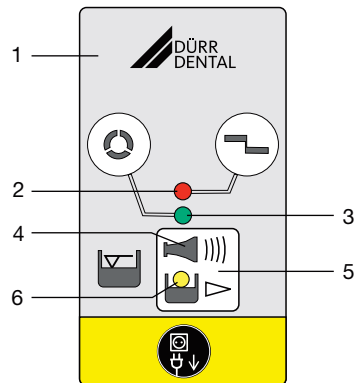
 Usage**11 Display/handling**

- 1 Display panel
- 2 RED display
- 3 GREEN LED
- 4 Audible signal/melody
- 5 Reset/service key
- 6 YELLOW LED

11.1 Ready for operation

-  Green LED is on

11.2 Amalgam collector vessel is 95% full

-  Yellow LED is on
-  Green LED is on

 Audible signal melody sounds

- At a fill level of 95%, the signal melody can be switched off by pressing the reset button. The device is then ready for operation again.
- The yellow LED comes on as a reminder that the amalgam collector vessel is due to be changed. The level display is repeated every time the unit is switched on at the main power switch.

 We recommend changing the amalgam collector vessel when it reaches 95% full.

11.3 Amalgam collector vessel is 100% full



-  Yellow LED is on
-  Red display flashes
-  Audible signal melody sounds

- At a fill level of 100% the signal melody can no longer be switched off by pressing the reset button.
- The collecting container needs to be replaced.

 Wear protective equipment to avoid any risk of infection (e.g. liquid-tight protective gloves, protective goggles, face mask).

- The separator will not be ready for operation again until the amalgam collecting container has been replaced



11.4 Amalgam collector vessel not in position

-  Red display flashes
-  Audible signal

- Press the reset button briefly to switch off the audible signal.
- Switch off the device.
- Insert the collecting container.
- Switch on the unit.
- Green LED lights up – "Ready for operation"

 If this error message occurs when the collecting container is correctly inserted, this indicates that there is a technical defect – inform your Service Technician.

11.5 Motor fault

-  Red display and
-  green LED flash alternately
-  Audible signal

- Press the reset button briefly to switch off the audible signal.
- If the reset button is pressed for longer than 2 seconds the unit can be restarted.
- Green LED lights up – "Ready for operation"

EN

 If, after pressing the reset button repeatedly, the fault report reappears again each time, this indicates a technical defect – inform your Service Technician.

12 Disinfection and cleaning



NOTICE

Device malfunctions or damage due to use of incorrect media

Guarantee claims may become invalid as a result.

- › Do not use any foaming agents such as household cleaning agents or instrument disinfectants.
- › Do not use abrasive cleaners.
- › Do not use agents containing chlorine.
- › Do not use any solvents like acetone.

Dürr Dental recommends

- For disinfection and cleaning:
Orotol plus or Orotol ultra
- For cleaning:
MD 555 cleaner

Only these products have been tested by Dürr Dental.

When using prophylaxis powders, Dürr Dental recommends the water-soluble Lunos prophylaxis powders in order to protect the Dürr Dental suction systems.

12.1 After every treatment

- › Aspirate a glass of cold water through the large and the small suction hoses. Do this even if only the small suction hose was actually used during treatment.



Suction through the large suction hose causes a large amount of air to be drawn up, thereby considerably increasing the cleaning effect.

12.2 Daily after the end of treatment



After higher workloads before the midday break and in the evening

The following are required for disinfection/cleaning:

- ✓ Non-foaming disinfectant/cleaning agent that is compatible with the materials.
- ✓ Unit care system, e.g. OroCup
- › To pre-clean, suck up 2 litres of water with the care system.
- › Aspirate the disinfection/cleaning agent with the care system.

12.3 Once or twice a week before the midday break



Under harsher conditions (e.g. hard water or frequent use of prophylaxis powders) 1x daily before the midday break

The following are required for cleaning:

- ✓ Special non-foaming detergent for suction units that is compatible with the materials.
- ✓ Unit care system, e.g. OroCup
- › To pre-clean, suck up 2 litres of water with the care system.
- › Aspirate the cleaning agent with the care system.
- › Rinse with ca. 2 l water after the application time.

13 Replace the amalgam collector vessel



NOTICE

Risk of contamination if the amalgam collector vessel is reused since the collector vessel is not water-tight.

- › Do not use the collecting container more than once (disposable item).

EN



Wear protective equipment to avoid any risk of infection (e.g. liquid-tight protective gloves, protective goggles, face mask).



We strongly recommend that the amalgam collecting container should only be changed in the morning before the start of work. This will prevent fluid from dripping out of the drum while it is being changed.

- › Disconnect all power from the unit.
- › Remove the full amalgam collecting container and from the device.
- › Pour disinfectant for suction units (e. g. Orotol plus, 30 ml) into the full amalgam collecting container.
- › Close and secure the full amalgam collecting container using the cap. Observe the markings on the cap and on the collecting container.
- › Place the securely closed amalgam collecting container into its original packaging and seal.
- › Insert a new amalgam collecting container in the unit and clamp it in position.



Only use original amalgam collecting container.

- › Switch on the power supply. The unit is ready for operation again.

13.1 Disposal of the collector vessel



Used amalgam collector vessels must not be sent in the post!



Dürr Dental is not a waste management company and is not allowed by law to accept any filled amalgam collector vessels.

› Arrange to have filled amalgam collector vessels collected from the surgery by a local waste management company.

EN

› New amalgam collector vessels should be ordered from your specialist dental equipment retailer.

› Document the replacement and legally compliant disposal of the filled waste amalgam collector vessel in the Operating Handbook.



In some countries the owner is required to keep an operating handbook. This operating handbook must document all maintenance work, service work, checks and amalgam disposal.

14 Maintenance



All maintenance work must be performed by a qualified expert or by one of our Service Technicians.

EN



WARNING

Infection due to contaminated unit

- › Clean and disinfect the suction before working on the unit.
- › Wear protective equipment when working (e. g. impermeable gloves, protective goggles and mouth and nose protection).



Prior to working on the unit or in case of danger, disconnect it from the mains.

Maintenance interval	Maintenance work
Dependent upon the level of usage of the device	<ul style="list-style-type: none"> › Replace the amalgam collecting container when a fill level of 95% or 100% is indicated on the display panel › Clean or replace protective sieves during replacement of the amalgam collecting container. At the latest, do this when the suction or draining power of the device decreases.
Annually	<ul style="list-style-type: none"> › Cleaning of the suction unit in accordance with the operating instructions. › Clean the float. * › Replace the bellows. *
Every 3 years	<ul style="list-style-type: none"> › Replace the rubber grommets on the connections. * › Replace the float. *
Every 5 years	<ul style="list-style-type: none"> › Replace the centrifuge drum and seal. * › Replace all O-rings (from the replacement parts kit) in the device. * › Replace the rubber grommets on the connections. * › Replace the float. *

* to be done by service technicians only

14.1 Tests

EN



WARNING

Infection due to contaminated unit

- › Clean and disinfect the suction before working on the unit.
- › Wear protective equipment when working (e. g. impermeable gloves, protective goggles and mouth and nose protection).



In some countries the owner is required to keep an operating handbook. This operating handbook must document all maintenance work, service work, checks and amalgam disposal.

Annual inspection

This inspection should only be carried out by suitably trained staff.

For inspection, the following are required:

- ✓ Test vessel

Work steps to be performed:

- › General functional check (e.g. aspiration, spittoon inlet)
- › Service program

The following measurement times apply to fill level measurements with a test vessel:

- For a fill level of 95%, the measurement result is displayed after approx. 30 sec, whereby the drive motor is briefly switched off during the measurement.
- At a fill level of 100% the measurement result is displayed after approx. 90 sec continuous running.

Inspection of the general operating condition every 5 years

This inspection must be carried out every 5 years (in accordance with the German Waste Water Regulations, Annex 50, Dental Treatment) by an inspector in accordance with national regulations.

For inspection, the following are required:

- ✓ Test vessel
- ✓ Measuring beaker

Work steps to be performed:

- › Fill the test vessel with water and insert it into the unit.
- › Start the device and wait until it switches off again.

- › Once the device has switched off, remove the test vessel and measure the remaining amount of water.

The unit is working correctly if:

- there is at minimum content of 140 ml in the **test vessel**.

If there is less fluid, clean the centrifuge drum or check the operation of the unit.

? Troubleshooting

15 Tips for operators and service technicians

EN

i Any repairs exceeding routine maintenance may only be carried out by qualified personnel or our service.



WARNING

Infection due to contaminated unit

- › Clean and disinfect the suction before working on the unit.
- › Wear protective equipment when working (e. g. impermeable gloves, protective goggles and mouth and nose protection).



Prior to working on the unit or in case of danger, disconnect it from the mains.

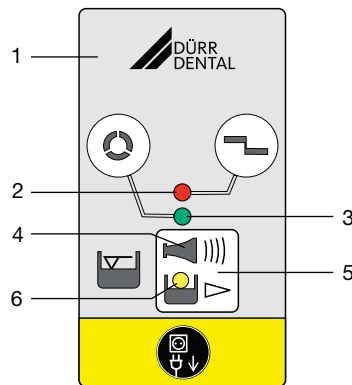

- 1 Display panel
- 2 RED display
- 3 GREEN LED
- 4 Audible signal/melody
- 5 Reset/service key
- 6 YELLOW LED

Error	Possible cause	Remedy
Device not "ready for operation" No display on the display panel.	The main power switch of the treatment unit or surgery is not switched on	› Main power switch ON
	If an external display panel is fitted: cable not correctly connected	› Check cable connections

? Troubleshooting

EN

Error	Possible cause	Remedy
Yellow display is on GREEN LED illuminates Audible signal melody sounds	Amalgam collecting container is 95% full	› Change the amalgam collecting container.
	Float sensor dirty or blocked	› If this display occurs repeatedly even when the collecting container is empty, check that the float sensor can move freely.
Yellow display is on Red display flashes Audible signal melody sounds	Amalgam collecting container is 100% full	› Change the amalgam collecting container. Audible signal can no longer be switched off.
	Float sensor dirty or blocked	› If this display occurs repeatedly even when the collecting container is empty, check that the float sensor can move freely.
	Waster water line/siphon trap dirty	› Clean the waste water line/siphon trap. *
The RED and GREEN displays flash alternately Audible signal	Motor is dirty or defective	› Check motor for smooth running; replace the centrifuge if necessary. * › Replace the device. *
	Contact problems at X9	› Plug in the connector correctly. * › Replace the PCB main board and connector on the motor. *
Orange LED flashes Audible signal		Press the service key briefly to switch off the audible signal
	Amalgam collecting container not correctly in position	› Switch OFF the device. › Insert the amalgam collecting container in the correct position. › Switch ON the device.
	Float sensor missing	› Insert the float sensor. *
Water accumulating in the spittoon	Coarse sieve in the fluid inlet blocked	› Clean the coarse sieve.
	Outlet ineffective or not vented	› Check or retrofit the ventilation. *
Suction power too weak or interrupted	Coarse sieve is blocked on the inlet of the aspiration	› Clean the coarse sieve.
	Place selection valve not or incompletely open	› Check the control voltage. * › Clean the place selection valve. *

Error	Possible cause	Remedy
Device running continuously	Float sensor blocked in water start position	<ul style="list-style-type: none"> › Clean the float. * › Free up the float sensor linkage so that it can move freely. *
	Start signal at the signal input (X2)	› Check the control voltage. *
	Waster water line/siphon trap dirty	› Clean the waste water line/siphon trap. *
Noise at the spittoon	Outlet ineffective or not vented	› Check or retrofit the ventilation. *
Increased vibration of the device	Pump cone dirty	› Clean or replace the pump cone. *
	Centrifuge dirty	› Clean or replace the centrifuge. *
	Water supply too low	<ul style="list-style-type: none"> › Introduce water into the suction pipe. › Retrofit the rinsing unit. * › Check the rinsing unit for its correct installation position. * › Check the function of the rinsing unit. *
Water cannot be pumped away or only insufficiently	Centrifuge dirty	› Clean or replace the centrifuge
	Waster water line/siphon trap dirty	› Clean the waste water line/siphon trap

EN

* Only to be done by service technicians.

16 Transporting the unit

EN



WARNING

Infection due to contaminated unit

- › Disinfect the unit before transport.
- › Close all media connections.



Wear protective equipment to avoid any risk of infection (e.g. liquid-tight protective gloves, protective goggles, face mask).

- › Before disassembly, clean and disinfect the suction unit and the unit using a suitable disinfectant approved by Dürr Dental.
- › Disinfect a defective unit using a suitable surface disinfection agent.
- › Seal all connections with sealing caps.
- › Pack the unit securely in preparation for transport.

16.1 Close CAS 1

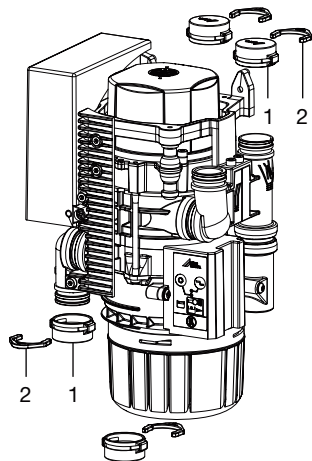

- 1 Dummy bushing
- 2 Ring clamp

 Appendix

EN

17 Handover record

This document confirms that a qualified handover of the medical device has taken place and that appropriate instructions have been provided for it. This must be carried out by a qualified adviser for the medical device, who will instruct you in the proper handling and operation of the medical device.

Product name	Order number (REF)	Serial number (SN)

- Visual inspection of the packaging for any damage
- Unpacking the medical device and checking for damage
- Confirmation of the completeness of the delivery
- Instruction in the proper handling and operation of the medical device based on the operating instructions

Notes:

Name of person receiving instruction:**Signature:**

Name and address of the qualified adviser for the medical device:

Date of handover:**Signature of the qualified adviser for the medical device:**

--	--



Hersteller/Manufacturer:

DÜRR DENTAL SE
Höpfigheimer Str. 17
74321 Bietigheim-Bissingen
Germany
Fon: +49 7142 705-0
www.duerrdental.com
info@duerrdental.com



CS 1 Combi-Sepamatic 24 V AC

EN

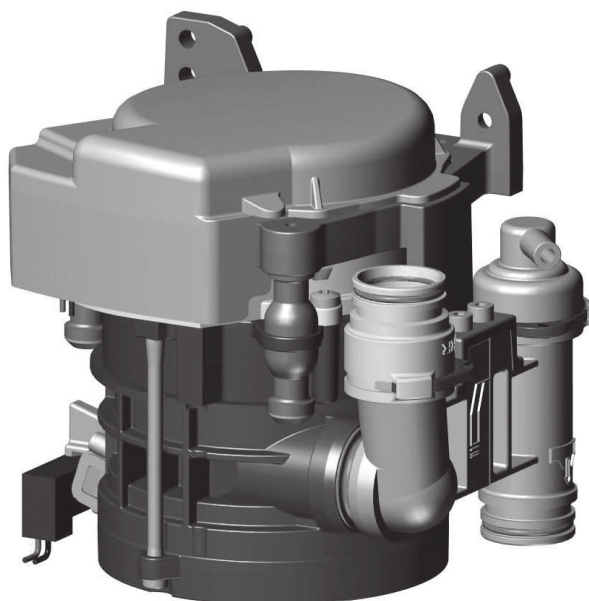

Installation and operating instructions

CE

9000-606-39/30



 **DÜRR
DENTAL** 2103V007

Contents



Important information

1 About this document	2
1.1 Warnings and symbols	2
1.2 Copyright information	3
2 Safety	3
2.1 Intended purpose	3
2.2 Intended use	3
2.3 Improper use	3
2.4 General safety information	4
2.5 Combining devices safely	4
2.6 Specialist personnel	4
2.7 Notification requirement of serious incidents	4
2.8 Electrical safety	4
2.9 Only use original parts	5
2.10 Transport	5
2.11 Disposal	5



Product description

3 Overview	6
3.1 Scope of delivery	6
3.2 Optional items	6
3.3 Consumables	6
3.4 Wear parts and replacement parts	6
4 Technical data	7
4.1 Type plate	11
4.2 Evaluation of conformity	11
5 Operation	12
5.1 Separation	12
5.2 Station selection valve	12



Assembly

6 Requirements	13
6.1 Setup options	13

6.2 Hose materials	13
6.3 Installation and routing of hoses and pipes	13
6.4 Information about electrical connections	13
6.5 Information about connecting cables	13
7 Installation	14
7.1 Installation of the CS 1 in treatment units	14
7.2 Power supply	15
7.3 Electrical connections, controller	15
7.4 Electrical connections	15
8 Commissioning	16

EN



Usage

9 Disinfection and cleaning	17
9.1 After every treatment	17
9.2 Daily after the end of treatment	17
9.3 Once or twice a week before the midday break	17
10 Maintenance	18



Troubleshooting

11 Tips for operators and service technicians	19
11.1 Replacing the fuse	20
12 Transporting the unit	20
12.1 Close the CS 1	20



Appendix

13 Handover record	21
-------------------------------------	----

! Important information

EN

1 About this document

These installation and operating instructions represent part of the unit.

 If the instructions and information in these installation and operating instructions are not followed, Dürr Dental will not be able to offer any warranty or assume any liability for the safe operation and the safe functioning of the unit.

The German version of the installation and operating instructions is the original manual. All other languages are translation of the original manual. These installation and operating instructions apply to:

CS 1
7117-100-70; 7117-100-70E; 7117-100-74;
7117-100-74E; 7117-100-76; 7117-100-77;
7117-100-78; 7117-100-79; 7117-100-80;
7117-100-80E

1.1 Warnings and symbols

Warnings

The warnings in this document are intended to draw your attention to possible injury to persons or damage to machinery.

The following warning symbols are used:

 General warning symbol

 Biohazard warning

The warnings are structured as follows:

 **SIGNAL WORD**
Description of the type and source of danger

Here you will find the possible consequences of ignoring the warning

› Follow these measures to avoid the danger.

The signal word differentiates between four levels of danger:

- **DANGER**
Immediate danger of severe injury or death
- **WARNING**
Possible danger of severe injury or death
- **CAUTION**
Risk of minor injuries
- **NOTICE**
Risk of extensive material/property damage

Other symbols

These symbols are used in the document and on or in the unit:

 Note, e.g. specific instructions regarding efficient and cost-effective use of the unit.

 Refer to Operating Instructions.

 Wear protective gloves.

 Disconnect all power from the unit.

 Hose manifold connection

 Suction unit connection

 Drain connection

 Order number

 Serial number

 Medical device

 Health Industry Bar Code (HIBC)

 CE labelling

 Protection class II

 Manufacturer

1.2 Copyright information

All circuits, processes, names, software programs and units mentioned in this document are protected by copyright.

The Installation and Operating Instructions must not be copied or reprinted, neither in full nor in part, without written authorisation from Dürr Dental.

2 Safety

Dürr Dental has designed and constructed this unit so that when used properly and for the intended purpose it does not pose any danger to people or property.

Despite this, the following residual risks can remain:

- Personal injury due to incorrect use/misuse
- Personal injury due to mechanical effects
- Personal injury due to electric shock
- Personal injury due to radiation
- Personal injury due to fire
- Personal injury due to thermal effects on skin
- Personal injury due to lack of hygiene, e.g. infection

2.1 Intended purpose

The separation system is designed for the continuous separation of air and liquids in the suction flow of dental treatment units.

2.2 Intended use

The separation system is intended for installation in the suction line of a dry suction system after the manifold.

Service, maintenance, recurring tests and cleaning must be performed in accordance with the manufacturer's information.

The permissible flow rate must be observed.

A rinsing unit is required for surgical procedures and for procedures using prophylaxis powders.

2.3 Improper use

Any use of this appliance / these appliances above and beyond that described in the Installation and Operating Instructions is deemed to be incorrect usage. The manufacturer cannot be held liable for any damage resulting from incorrect usage. The operator will be held liable and bears all risks.

This includes:

EN

! Important information

EN

- Use for separation of dust, sludge, plaster or similar.
- Use in conjunction with flammable or explosive mixtures.
- Installation in a manner that does not comply with the installation instructions, in particular installation in rooms containing a potentially explosive atmosphere.
- Cleaning and disinfection with agents containing sodium hypochlorite or potassium hypochlorite.

2.4 General safety information

- › Always comply with the specifications of all guidelines, laws, and other rules and regulations applicable at the site of operation for the operation of this unit.
- › Check the function and condition of the unit prior to every use.
- › Do not convert or modify the unit.
- › Comply with the specifications of the Installation and Operating Instructions.
- › The Installation and Operating Instructions must be accessible to all operators of the unit at all times.

2.5 Combining devices safely

Take care when connecting units together or to parts of other systems as there is always an element of risk (e.g. due to leakage currents).

- › Only connect units when there can be no question of danger to operator or to patient.
- › Only connect units when it is safe to do so and when there is no risk of damage or harm to the surroundings.
- › If it is not 100% clear from the unit data sheet that such connections can be safely made or if you are in any doubt, always get a suitably qualified person (e.g. the manufacturer) to verify that the setup is safe.

Where applicable, the requirements for medical products have been taken into account in the development and construction of the device. As a result, this device is suitable for installation within medical supply equipment.

- › Where this device is integrated in other medical supply equipment, the requirements of European Union Medical Device Regulation 2017/745 and the relevant standards must be observed.

2.6 Specialist personnel

Operation

Unit operating personnel must ensure safe and correct handling based on their training and knowledge.

- › Instruct or have every user instructed in handling the unit.

Installation and repairs

- › Installation, readjustments, alterations, upgrades and repairs must be carried out by Dürre Dental or by qualified personnel specifically approved and authorized by Dürre Dental.

2.7 Notification requirement of serious incidents

The operator/patient is required to report any serious incident that occurs in connection with the device to the manufacturer and to the competent authority of the Member State in which the operator and/or patient is established/resident.

2.8 Electrical safety

- › Comply with all the relevant electrical safety regulations when working on the unit.
- › Never touch the patient and unshielded plug connections on the device at the same time.
- › Replace any damaged cables or plugs immediately.

Observe the EMC rules concerning medical devices

- › The unit is intended for use in professional healthcare facilities (in accordance with IEC 60601-1-2). If the appliance is operated in another environment, potential effects on electromagnetic compatibility must be taken into account.
- › Do not operate the unit in the vicinity of HF surgical instruments or MRT equipment.
- › Keep a minimum distance of 30 cm between the unit and mobile radio devices.
- › Note that cable lengths and cable extensions have effects on electromagnetic compatibility.

**NOTICE****Negative effects on the EMC due to non-authorised accessories**

- › Use only Dürr Dental parts or accessories specifically approved by Dürr Dental.
- › Using any other accessories may result in increased electromagnetic interference emissions or the unit having reduced electromagnetic immunity, leading to an erroneous operation mode.

**NOTICE****Erroneous operation mode due to use immediately adjacent to other devices or with other stacked devices**

- › Do not stack the unit together with other devices.
- › If this is unavoidable, the unit and other devices should be monitored in order to ensure that they are working correctly.

2.9 Only use original parts

- › Only use accessories and optional items that have been recommended or specifically approved by Dürr Dental.
- › Only use only original wear parts and replacement parts.



DÜRR MEDICAL accepts no liability for damages or injury resulting from the use of non-approved accessories or optional accessories, or from the use of non-original wear parts or replacement parts. The use of non-approved accessories, optional accessories or non-genuine wear parts / replacement parts (e.g. mains cables) can have a negative effect in terms of electrical safety and EMC.

2.10 Transport

The original packaging provides optimum protection for the unit during transport. If required, original packaging for the unit can be ordered from Dürr Dental.



Dürr Dental will not accept any responsibility or liability for damage occurring during transport due to the use of incorrect packaging, even where the unit is still under guarantee.

- › Only transport the unit in its original packaging.
- › Keep the packing materials out of the reach of children.

2.11 Disposal

The unit may be contaminated. Instruct the company disposing of the waste to take the relevant safety precautions.

- › Decontaminate potentially contaminated parts before disposing of them.
- › Uncontaminated parts (e.g. electronics, plastic and metal parts etc.) should be disposed of in accordance with the local waste disposal regulations.
- › If you have any questions about the correct disposal of parts, please contact your dental trade supplier.



An overview of the waste keys for Dürr Dental products can be found in the download area at:
www.duerrdental.com
Document no.: P007100155

EN

Product description

EN

3 Overview

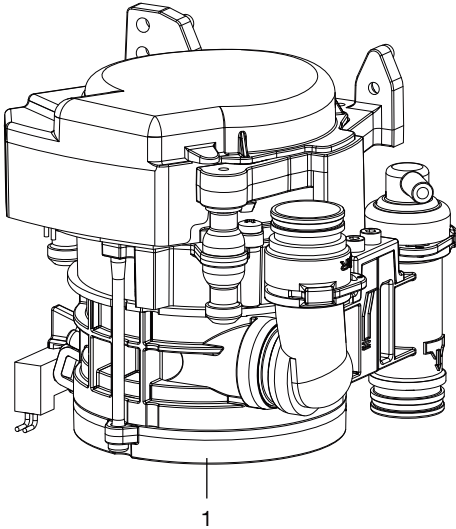

1 CS 1 Combi-Sepamatic

3.1 Scope of delivery

i The scope of delivery can vary slightly depending on the version.

The following items are included in the scope of delivery:

- CS 1 7117-100-7x
- or
- CS 1 7117-100-8x
- Combi-Sepamatic
- or Combi-Sepamatic inc. station selection valve
- Rinsing unit
- Installation and Operating Instructions

3.2 Optional items

The following optional items can be used with the device:

- Various installation sets are available on request
- Safety transformer 24 V, 100 VA .. 9000-150-46
- Station selection valve for CAS 1 /
- CS 1 7560-500-80
- Station selection valve 7560-500-60
- Vario rinsing unit 7100-260-51
- Rinsing unit II 7100-250-50
- OroCup care system 0780-350-00

3.3 Consumables

The following materials are consumed during operation of the device and must be ordered separately:

- DürrConnect protective strainer,
- 5 pieces 0700-700-18E
- Orotol plus (2.5 litre bottle) CDS110P6150
- MD 550 spittoon bowl cleaner
- (750 ml bottle) CCS550C4500
- MD 555 cleaner (2.5 litre bottle) CCS555C6150

3.4 Wear parts and replacement parts

The following working parts need to be changed at regular intervals (refer to the "Maintenance" section):

- Protective strainer
- Rubber grommets
- O-rings

Replacement parts set (3 years) .. 7117-980-33

O-ring set for CS 1 7117-980-22

i Information about replacement parts is available from the portal for authorised specialist dealers at:
www.duerrdental.net

4 Technical data

Electrical data – centrifuge motor		7117-100-7x 7117-100-8x
Rated voltage	V	24 AC
Frequency	Hz	50 / 60
Rated power	VA	70
Nominal current in standby	mA	80
Signal input from the hose manifold	V	24 AC
	Hz	50/60
Signal output	V	24 DC
	mA	300
Media		
Fluid volume		
min.	l/min	≥ 0.1
max.	l/min	≤ 2.0
Air flow volume	l/min	≤ 350
Flow rate		high
The suction system must be suitable for a high flow rate in accordance with EN ISO 10637.		
Max. pressure	hPa/mbar	-160
General data		
Operating mode	%	100 (S1)
Type of protection		IP 20
Protection class		II
Noise level, approx.*	dB(A)	45
Dimensions (H x W x D)	cm	15 x 16 x 12
Weight, approx.	kg	1.4
* in accordance with EN ISO 3746		
Ambient conditions during storage and transport		
Temperature	°C	-10 to +60
Relative humidity	%	< 95
Ambient conditions during operation		
Temperature	°C	+10 to +40
Relative humidity	%	< 70
Classification		
Medical Device Class		I

EN

Electromagnetic compatibility (EMC)		
Interference emission measurements		
EN	High-frequency emissions in accordance with CISPR 11	Group 1 Class B
	Interference voltage at the power supply connection CISPR 11:2009+A1:2010	Compliant
	Electromagnetic interference radiation CISPR 11:2009+A1:2010	Compliant
	Emission of harmonics IEC 61000-3-2:2005+A1:2008+A2:2009	N/A
	Voltage changes, voltage fluctuations and flicker emissions IEC 61000-3-3:2013	N/A
	N/A = not applicable	
Electromagnetic compatibility (EMC)		
Interference immunity measurements		
	Immunity to electrostatic discharge IEC 61000-4-2:2008	Compliant
	Immunity to high-frequency electromagnetic fields IEC 61000-4-3:2006+A1:2007+A2:2010	Compliant
	Immunity to near fields of wireless HF communication devices IEC 61000-4-3:2006+A1:2007+A2:2010	Compliant
	Immunity to fast electrical transients/bursts – AC mains voltage IEC 61000-4-4:2012	Compliant
	Immunity to electrical fast transients/bursts – I/O, SIP/SOP ports IEC 61000-4-4:2012	Compliant
	Immunity to interference, surges IEC 61000-4-5:2005	Compliant
	Immunity to conducted disturbances, induced by radio-frequency fields – AC mains voltage IEC 61000-4-6:2013	Compliant
	Immunity to conducted disturbances, induced by radio-frequency fields – SIP/SOP ports IEC 61000-4-6:2013	Compliant
	Immunity to power frequency magnetic fields IEC 61000-4-8:2009	Compliant
	Immunity to voltage dips, short interruptions and voltage variations IEC 61000-4-11:2004	Compliant

Electromagnetic compatibility (EMC)		
Interference immunity measurements on the supply input		
Immunity to fast electrical transients/bursts – AC mains voltage IEC 61000-4-4:2012 ± 2 kV 100 kHz repetition rate	Compliant	EN
Immunity to surges, line-to-line IEC 61000-4-5:2005 ± 0.5 kV, ± 1 kV	Compliant	
Immunity to conducted disturbances, induced by radio-frequency fields – AC mains voltage IEC 61000-4-6:2013 3 V 0.15–80 MHz 6 V ISM frequency bands 0.15–80 MHz 80% AM at 1 kHz	Compliant	
Immunity to voltage dips, short interruptions and voltage variations IEC 61000-4-11:2004	Compliant	
Electromagnetic compatibility (EMC)		
Interference immunity measurements SIP/SOP		
Immunity to electrical fast transients/bursts – I/O, SIP/SOP ports IEC 61000-4-4:2012 ± 1 kV 100 kHz repetition rate	Compliant	
Immunity to conducted disturbances, induced by radio-frequency fields – SIP/SOP ports IEC 61000-4-6:2013 3 V 0.15–80 MHz 6 V ISM frequency bands 0.15–80 MHz 80% AM at 1 kHz	Compliant	
Immunity to interference table, near fields of wireless HF communication devices		
Radio service	Frequency band MHz	Test level V/m
TETRA 400	380 - 390	27
GMRS 460 FRS 460	430 - 470	28
LTE band 13, 17	704 - 787	9

Immunity to interference table, near fields of wireless HF communication devices				
Radio service	Frequency band MHz	Test level V/m		
EN GSM 800/900 TETRA 800 iDEN 820 CDMA 850 LTE band 5	800 - 960	28		
	GSM 1800 CDMA 1900 GSM 1900 DECT LTE band 1, 3, 4, 25 UMTS	1700 - 1990	28	
		Bluetooth WLAN 802.11 b/g/n RFID 2450 LTE band 7	2400 - 2570	28
			WLAN 802.11 a/n	5100 - 5800

4.1 Type plate

The type plates are on the motor cover and on the motor flange.

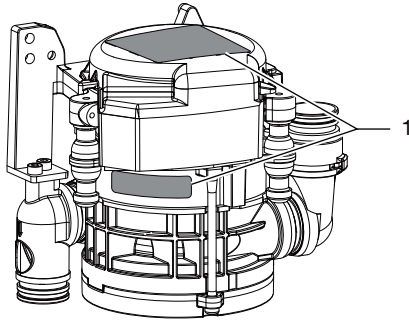

1 Type plate

4.2 Evaluation of conformity

This device has been subjected to conformity acceptance testing in accordance with the current relevant European Union guidelines. This equipment conforms to all relevant requirements.

EN

5 Operation

EN

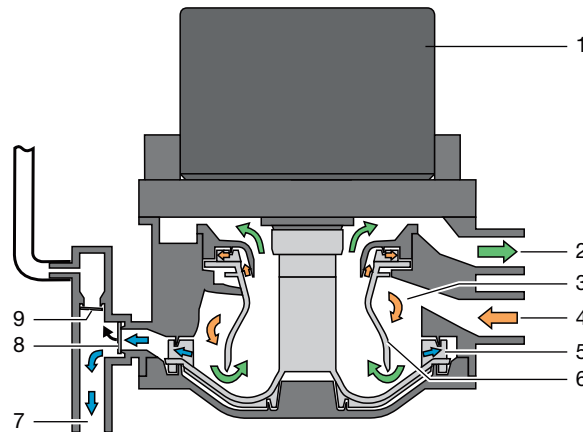

- 1 Motor
- 2 Vacuum, to suction unit
- 3 Separation
- 4 Aspiration input
- 5 Pump wheel
- 6 Separation rotor
- 7 Fluid output
- 8 Waste valve
- 9 Relief valve

5.1 Separation

Every time the suction hose is taken out of the hose manifold, the CS 1 Combi-Sepamatic and the suction unit are started.

The mixture of liquid and air drawn up is accelerated in the intake connection and then set in spiral motion in the separation. The resulting centrifugal forces sling the aspirated particles against the outer wall. The air is continuously separated from the fluid and escapes to the suction unit via the spinning separation rotor.

The aspirated air is subject to high centrifugal forces by the separation rotor, which ensures that no fluid or blood foam can be carried into the suction unit.

The spiral motion serves to continuously transport the separated liquid to the pump wheel, this then pumps the liquid into the central waste water drainage system via the waste water valve.

The air bleed is carried out via the relief valve. If fluid escapes upwards into the air bleed area following a fault, the relief valve closes automatically.

5.2 Station selection valve

The station selection valve interrupts the suction flow between the hose manifold and the suction unit.

As soon as a suction hose has been removed from the hose manifold, the station selection valve is opened and suction flow is enabled.

A station selection valve is already integrated in various versions of the CS 1. An external station selection valve can be electrically controlled via the CS 1.

Assembly

EN

6 Requirements

6.1 Setup options

CS 1 Combi-Sepamatic

- Directly in the treatment unit.
- In a special housing in an extension of the treatment unit.

6.2 Hose materials

For waste connections and suction lines only use the following hose types:

- Flexible spiral hoses made of PVC with integrated spiral or equivalent hoses
- Hoses that are resistant to dental disinfectants and chemicals



Plastic hoses will display signs of ageing over time. Therefore, they should be inspected regularly and replaced as necessary.

The following types of hoses must not be used:

- Rubber hoses
- Hoses made completely of PVC
- Hoses that are not sufficiently flexible

6.3 Installation and routing of hoses and pipes

- › Execute the on-site pipe installation in accordance with the applicable local regulations and standards.
- › Lay the hose installation of the drains to or from the unit at a sufficient incline.



If incorrectly laid, the hoses can become blocked with sedimentation.

6.4 Information about electrical connections

- › Ensure that the electrical connections to the mains power supply are established in accordance with current valid national and local regulations and standards governing the installation of low voltage units in medical facilities.

- › Install an all-pole disconnect switch with a contact opening width of at least 3 mm in the electrical connection to the mains power supply. It must be possible to secure the disconnect switch so that it cannot be inadvertently switched back on again.
- › Install electrical lines without mechanical tension.
- › Make the electrical connection via the main power switch of the treatment unit or via the main power switch of the practice.

6.5 Information about connecting cables

Mains supply cable

Installation type	Line layout (minimum requirements)
Fixed installation	– Plastic sheathed cable (e.g. type NYM-J)
Flexible	– PVC flexible line (e.g. H05 VV-F) or – Rubber connection (e.g. H05 RN-F or H05 RR-F)

Control cable

Installation type	Line layout (minimum requirements)
Fixed installation	– Shielded sheathed cable (e.g. (N)YM (St)-J)
Flexible	– PVC data cable with shielded cable sheathing, as used for telecommunications and IT processing systems (e.g. type LiYCY) or – Lightweight PVC control cable with shielded cable sheathing

Wire cross-section

Unit feed:

- 0.75 mm²

Connection external valves / units:

- 0.5 mm²

7 Installation

EN



WARNING

Infection due to contaminated unit

- Clean and disinfect the suction before working on the unit.
- Wear protective equipment when working (e. g. impermeable gloves, protective goggles and mouth and nose protection).



Prior to working on the unit or in case of danger, disconnect it from the mains.

7.1 Installation of the CS 1 in treatment units

Attach the unit vertically at a suitable position in the treatment unit. The unit is mounted on rubber pads and suspended in a metal frame. This mounting arrangement prevents the transmission of any vibrations to the treatment unit while the device is running. Vibrations may occur if the unit is not positioned vertically. A minimum distance of 3 mm must be maintained to the surroundings.

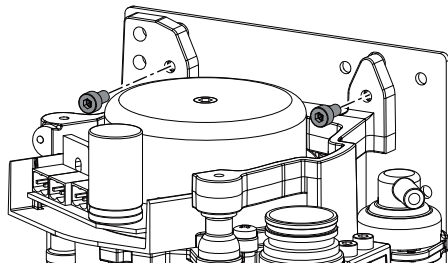

Station selection valve

In various types, the place selection valve is directly mounted on the CS 1. The station selection valve (for separate installation) should be fitted in the suction pipe in the treatment unit, preferably near the end connection in the floor socket. The electrical connection should then also be carried out on the CS 1. For further information, refer to the station selection valve installation and operating instructions

Inlet and outlet hoses

Connect and attach the inlet and outlet hoses with DürrConnect connectors to the relevant connections on the unit. Route the hoses at an incline.

Recommended diameter of the connection hoses: \varnothing 25 mm.

The minimum nominal width for the outlet hose is 15 mm.

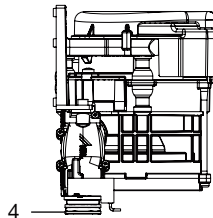
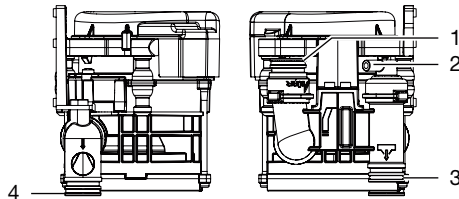

- 1 Hose manifold
- 2 Vent
- 3 Outlet
- 4 Suction unit

Rinsing unit

It is recommended that the suction system is equipped with a rinsing unit, e.g. in the treatment unit. The rinsing unit provides a small amount of water during aspiration. This dilutes the aspirated fluids (blood, saliva, rinsing water etc.), which can then be transported more effectively.

Installation sets

Installation sets and detailed documentation for various installation situations are available from the manufacturers.



When installed in a housing, ventilation slits should be provided to avoid heat build-up in the housing.

7.2 Power supply

- Safety transformer order number:
9000-150-46
- Safety transformer 24 V AC with an isolator consisting of two means of patient protection (MOPP) between the mains circuit and secondary circuit, min. 100 VA, secondary fuse T 4 AH (or IEC 60127-2/V T 4 AH, 250 V)

7.3 Electrical connections, controller

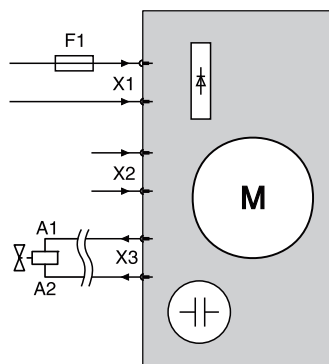

- X1 Power supply in accordance with EN 60601-1
- X2 Signal input / start signal
- X3 Place selection valve and/or rinsing unit
24 V DC (max. output: 8 W)
- F1 T 4 AH, 250 V in accordance with IEC 60127-2

7.4 Electrical connections

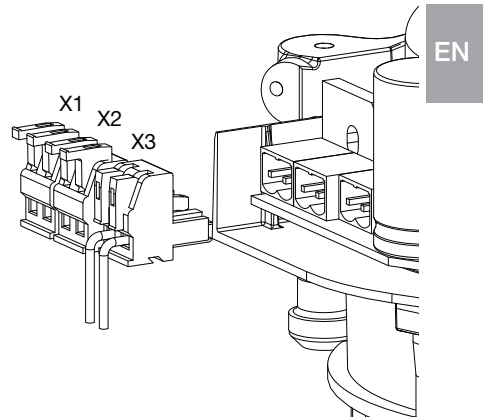

- X1 Power supply
- X2 Hose manifold start signal
- X3 Outgoing signal station selection valve and/or rinsing unit

- > Remove the motor cover of the CS 1.
- > Attach the connector to the connection lines.



To open, lift the terminal lever upwards.

- > Plug the connector onto the control.
- > Put the motor cover on.

8 Commissioning

EN



In many countries technical medical products and electrical devices are subject to regular checks at set intervals. The owner must be instructed accordingly.

- › Turn on the unit power switch or the main surgery switch.
- › Carry out an electrical safety check in accordance with applicable local regulations (e.g. the German Ordinance on the Installation, Operation and Use of Medical Devices / Medizinprodukte-Betreiberverordnung) and record the results as appropriate, e.g. in the technical log book.
- › Check the aspiration function.
- › Check the connections, hoses and device for leaks.

 Usage

9 Disinfection and cleaning



NOTICE

Device malfunctions or damage due to use of incorrect media

Guarantee claims may become invalid as a result.

- › Do not use any foaming agents such as household cleaning agents or instrument disinfectants.
- › Do not use abrasive cleaners.
- › Do not use agents containing chlorine.
- › Do not use any solvents like acetone.

Dürr Dental recommends

- For disinfection and cleaning: Orotol plus or Orotol ultra
- For cleaning: MD 555 cleaner

Only these products have been tested by Dürr Dental.

When using prophy powders, Dürr Dental recommends the water-soluble Lunos prophy powders in order to protect the Dürr Dental suction systems.

9.1 After every treatment

- › Aspirate a glass of cold water through the large and the small suction hoses. Do this even if only the small suction hose was actually used during treatment.



Suction through the large suction hose causes a large amount of air to be drawn up, thereby considerably increasing the cleaning effect.

9.2 Daily after the end of treatment



After higher workloads before the midday break and in the evening

The following are required for disinfection/cleaning:

- ✓ Non-foaming disinfectant/cleaning agent that is compatible with the materials.
- ✓ Unit care system, e.g. OroCup
- › To pre-clean, suck up 2 litres of water with the care system.
- › Aspirate the disinfection/cleaning agent with the care system.

9.3 Once or twice a week before the midday break



Under harsher conditions (e.g. hard water or frequent use of prophy powders) 1x daily before the midday break

The following are required for cleaning:

- ✓ Special non-foaming detergent for suction units that is compatible with the materials.
- ✓ Unit care system, e.g. OroCup
- › To pre-clean, suck up 2 litres of water with the care system.
- › Aspirate the cleaning agent with the care system.
- › Rinse with ca. 2 l water after the application time.

EN

10 Maintenance

EN



All maintenance work must be performed by a qualified expert or by one of our Service Technicians.



WARNING

Infection due to contaminated unit

- › Clean and disinfect the suction before working on the unit.
- › Wear protective equipment when working (e. g. impermeable gloves, protective goggles and mouth and nose protection).



Prior to working on the unit or in case of danger, disconnect it from the mains.

Maintenance interval

Maintenance work

Dependent upon the level of usage of the device

- › Clean or replace the protective sieves at the aspiration inlet. At the latest, however, when the suction power of the unit diminishes.

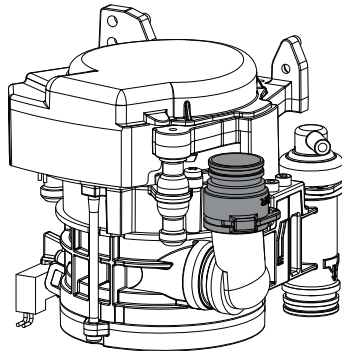

Annually	<ul style="list-style-type: none"> › Cleaning of the suction unit in accordance with the operating instructions. › Clean or replace the protective sieves at the aspiration inlet. › If a rinsing unit is present: clean the sieve in the water supply. * › Perform a functional test. *
Every 3 years	<ul style="list-style-type: none"> › Replace the rubber grommets on the connections. *
Every 5 years	<ul style="list-style-type: none"> › Replace the rubber grommets on the connections. * › Replace all o-rings in the device. *

* Only by customer services service technicians.

? Troubleshooting

11 Tips for operators and service technicians

EN



Any repairs exceeding routine maintenance may only be carried out by qualified personnel or our service.



WARNING

Infection due to contaminated unit

- › Clean and disinfect the suction before working on the unit.
- › Wear protective equipment when working (e. g. impermeable gloves, protective goggles and mouth and nose protection).



Prior to working on the unit or in case of danger, disconnect it from the mains.

Error	Possible cause	Remedy
Device does not start	No power supply	<ul style="list-style-type: none"> › Check power supply. * › Check the fuses and replace if necessary. *
	No start signal	<ul style="list-style-type: none"> › Check the control voltage at the signal input. *
Suction power too weak or interrupted	Coarse sieve is blocked on the inlet of the aspiration	<ul style="list-style-type: none"> › Clean the coarse sieve.
	Place selection valve not or incompletely open	<ul style="list-style-type: none"> › Check the control voltage. * › Clean the place selection valve. *

* Only to be done by service technicians.

11.1 Replacing the fuse

EN



Prior to working on the unit or in case of danger, disconnect it from the mains.

Transformer

- › Unscrew and remove the safety cover.
- › Replace the fuse.

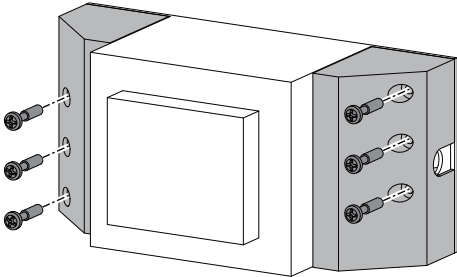

Fuse housing

- › Turn the fuse housing to open it.
- › Replace the fuse.

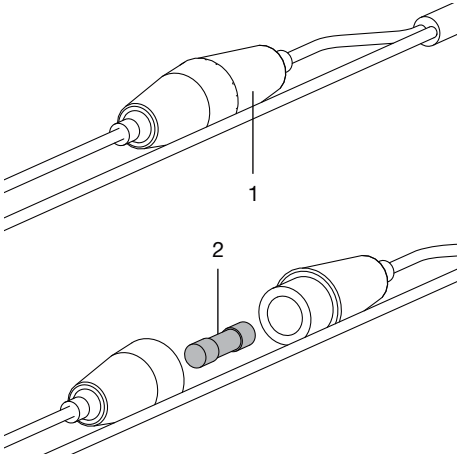

- 1 Fuse housing
- 2 Fuses

12 Transporting the unit



WARNING

Infection due to contaminated unit

- › Disinfect the unit before transport.
- › Close all media connections.



Wear protective equipment to avoid any risk of infection (e.g. liquid-tight protective gloves, protective goggles, face mask).

- › Before disassembly, clean and disinfect the suction unit and the unit using a suitable disinfectant approved by Dürr Dental.
- › Disinfect a defective unit using a suitable surface disinfection agent.
- › Seal all connections with sealing caps.
- › Pack the unit securely in preparation for transport.

12.1 Close the CS 1

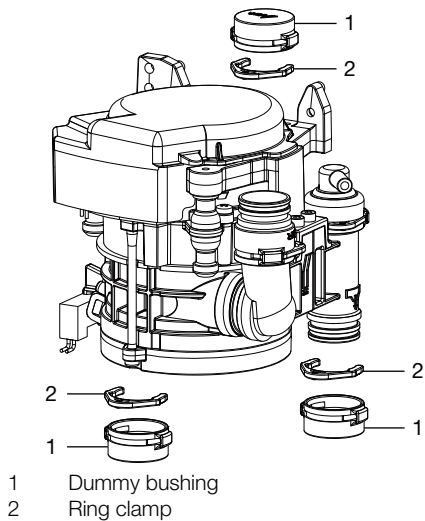

- 1 Dummy bushing
- 2 Ring clamp

 Appendix

EN

13 Handover record

This document confirms that a qualified handover of the medical device has taken place and that appropriate instructions have been provided for it. This must be carried out by a qualified adviser for the medical device, who will instruct you in the proper handling and operation of the medical device.

Product name	Order number (REF)	Serial number (SN)

- Visual inspection of the packaging for any damage
- Unpacking the medical device and checking for damage
- Confirmation of the completeness of the delivery
- Instruction in the proper handling and operation of the medical device based on the operating instructions

Notes:

Name of person receiving instruction:**Signature:**

Name and address of the qualified adviser for the medical device:

Date of handover:**Signature of the qualified adviser for the medical device:**

--	--

EN



Hersteller / Manufacturer:

DÜRR DENTAL SE
Höpfigheimer Str. 17
74321 Bietigheim-Bissingen
Germany
Fon: +49 7142 705-0
www.duerrdental.com
info@duerrdental.com





EVA

USER MANUAL



EXPERIENCE AND INNOVATION
SINCE 1948

TABLE OF CONTENTS

1	SYMBOLS USED	3
1.1	SYMBOLS USED IN THIS MANUAL	3
1.2	SYMBOLS USED IN THE LABELLING AND ON THE PACKAGING	3
2	INTENDED USE.....	4
2.1	INTENDED USER	4
2.1.1	Professional qualification.....	4
2.1.2	Minimum skills.....	4
2.1.3	Experience	4
2.1.4	Possible user handicaps.....	4
3	DESCRIPTION OF THE PRODUCT.....	5
3.1	DESCRIPTION OF COMMON USER'S INTERFACE	6
4	INSTRUCTION FOR USE	6
4.1	SWITCHING ON/ OFF.....	6
4.2	ADJUSTING THE LIGHT INTENSITY	6
4.3	CHANGING COLOR TEMPERATURE ON TUNABLE WHITE VERSION	7
4.4	COMPOSAVE SETTING ON TUNABLE WHITE VERSION	8
4.5	MINIMUM INTENSITY SETTING ON SOLAR VERSION	8
4.6	AUTO-ON SETTING	8
4.7	SWITCHING ON/ OFF THEIA.....	8
4.8	REMOTE CONTROL.....	8
4.9	SYNCRO MODE WITH FARO ROOM LIGHT	9
5	PREVENTIVE MAINTENANCE AND ROUTINE CHECKS	10
6	CLEANING AND DISINFECTION.....	11
6.1	CLEANING OF THE REFLECTING PARABOLAS	11
6.2	CLEANING AND DISINFECTION OF THE HEAD	11
6.3	CLEANING AND DISINFECTION OF ARMS.....	11
7	STERILIZATION OF THE HANDLES	11
7.1	REMOVAL OF THE HANDLES	11
7.2	DECONTAMINATION AND DISINFECTION.....	11
7.3	STERILIZATION	11
8	TROUBLESHOOTING.....	12
8.1	ERROR LIST.....	12
9	TECHCNICAL SPECIFICATIONS.....	12
9.1	STORAGE AND TRANSPORTATION: ENVIRONMENTAL CONDITIONS.....	13
9.2	USE: ENVIRONMENTAL CONDITIONS.....	13

Dear Customer,

FARO hopes you enjoy your work with the new high quality light. For safe work and to take full advantage of the performance of the product, read carefully this manual before using the device.

In particular, follow all the warnings and the notes described into the Safety Recommendations included in the Packaging .

Warranty Conditions:

FARO offers the final customer a **24 month warranty** starting from the date of installation until a maximum of 30 months from the manufacturing date.

Repairs under warranty must be performed by FARO or its approved Service network.

Warranty is considered valid only when:

- the user sent the Certificate of Warranty duly filled out at the following email: service@faro.it
- the user registered the warranty throughout the Faro website;

The warranty covers manufacturing and engineering defects; in case of valid claims, the warranty covers free parts replacement only. Manhour work is not included in the warranty.





The warranty is not considered valid, at the sole discretion of FARO, if the fault is due to tampering, damage, unauthorized changes to the product, incorrect use, improper maintenance and normal wear and tear.

This product have a Service Life of: 10 Years.

Any serious incident occurring in relation to the device should be reported to the Manufacturer and the competent authority of the Member State in which the user and/or patient is established.

1 SYMBOLS USED

1.1 SYMBOLS USED IN THIS MANUAL

	<i>WARNING</i>
The paragraphs marked with this symbol contain instructions that must be carefully followed to avoid damaging the device, harming the operator or the patient.	
	<i>CAUTION</i>
These instructions warns you that you must pay attention to avoid situations that could damage the device.	
	<i>FORBIDDEN</i>
This icon highlights what you should not do to avoid damaging the device.	
	<i>NOTES</i>
This icon supplies information that allows you to use the device more efficiently.	

1.2 SYMBOLS USED IN THE LABELLING AND ON THE PACKAGING

The data plate is fixed:

- for the complete light or arms: on the rear arm
- for the head: under the heat sink cover

Serial Number description







- For dental light YYLDNNNNNN
- For head of dental light YYTENNNNNN













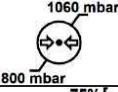



Where

- YY: last two digit of the year of manufacturing
- NNNNNN: progressive counter of the year

e.g.: 2ILD000001 I the first product manufactured in 2021.

The following standardized symbols are also present:

Symbol	Description
	Mark for Conformitè Europe
	Medical Device according to Regulation (EU) 2017/745 of the European Parliament and of the Council of 5 April 2017 on medical devices,
	Read the instructions use. Supplied by Electronic means.
	Manufacturer symbol according to Regulation (EU) 2017/745
	The instructions for use include safety warnings
	WEEE equipment according to the Directive 2012/19/EC. Dispose of the product according to this directive.
	Double insulation. Class 2 device against electrical risk

Symbol	Description
	Serial Number
	Can be sterilized with heat at 134°C
	Use the device at a temperature between 10°C and 40°C
	Use the device at pressure between 80 kPa and 106 kPa
	Use the device at relative humidity between 30 RH and 75RH
	Symbol to adjust light intensity
	Symbol to switch on/off the light
	Symbol to switch on/off the light on the rear arm (Alya with Theia Tech)
	High
	Fragile
	Protect the packaging from rain and high humidity
	Do not Roll
	Do not use hooks
	Maximum stackable weight
	Storage and Transportation temperatures
	Storage and Transportation Relative Humidity
	Storage and Transportation Atmospheric Pressure
	Recyclable cardboard

2 INTENDED USE

The device is used in dental office and is intended for illuminating the oral cavity and oral structures of patients in dentistry. In the normal use, the device is positioned distance of 700mm from the operative area, the distance for which the lighting features were designed. Patients can be of all ages with typical dental pathologies.

2.1 INTENDED USER

The intended users are Dentists (all specializations) or Dental Nurse, Hygienists and Assistants

2.1.1 Professional qualification:

Degree in Medicine with Dentistry Specialization

Degree in Dentistry

Degree in dental nursery

2.1.2 Minimum skills

Those planned for the professional qualification

Understanding of language: Those acquired for the professional qualification

2.1.3 Experience

Those outlined to conduct the profession

2.1.4 Possible user handicaps

For the use it is necessary at least one upper limb;

Visual faculty compatible with the profession;

The user with these characteristics does not require any special training

3 DESCRIPTION OF THE PRODUCT

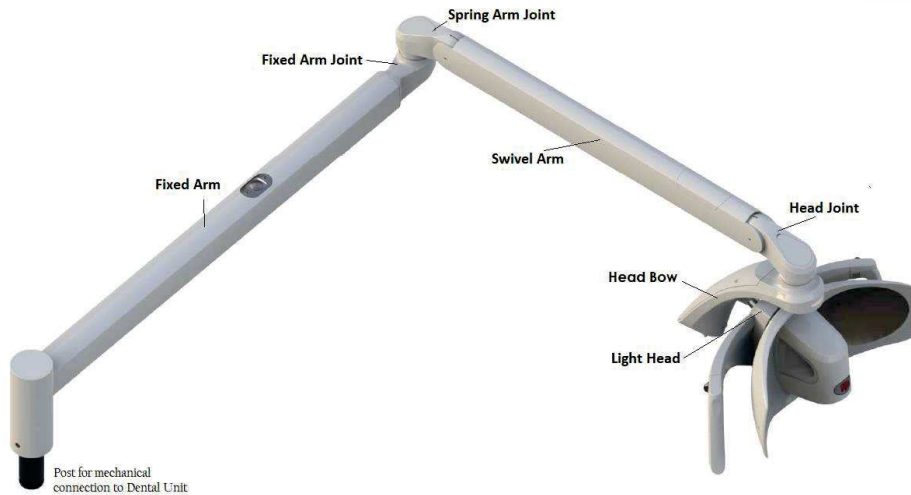

Picture 1 –Dental Light – Unit Mount



Picture 2 –Dental Light – Ceiling Mount

The device is available in two main product variants:

- EVA with light source at 5000 K with “Sunlight” Spectrum
- EVA with Tunable White light source (4000 K, 5000 K, 5700 K, Composable setting (2700 K)) selectable by the operator.

These main variants can be supplied with:

- Different Mounting;
- Different arm length combination
- Canbus Technology
- Remote cable for bring the command to the Dental Unit’s
- Auto-on setting;
- Theia Technology (secondary light source under fixed arm);
- Integrated Camera 2K or 4K;
- RF for the connection with FARO’s room lights (Siderèa)

All variants can be ordered by dedicated product codes as reported in the table below:

Mounting		Swivel Arm		Fixed Arm		Light Source / Integrated Camera		Command / radiofrequency (RF)		Cables		Custom ⁽¹⁾	
1-2 DIGIT		3° DIGIT		4° DIGIT		5° DIGIT		6° DIGIT		7° DIGIT		8°-9° DIGIT	
5	U	0	Only Head No arms	0	Only Head No arms	0	Tunable White	0	Joystick	0	Standard	00	Std faro
5	C	1	550 mm	1	600 mm	1	Sunlight 5000K	1	Joystick RF	1	Remote Control Bus Cable	JJ	(4)
5	T	2	855 mm	2	600 mm Theia	2	Tunable White Integrated Camera	2	Sensor				
				3	820 mm	3	Sunlight 5000K Integrated Camera	3	Sensor RF				
				4	820 mm Theia	4	cNus Tunable ⁽²⁾⁽³⁾						
				5	960 mm	5	cNus Sunlight 5000K ⁽²⁾⁽³⁾						
				6	960 mm Theia								

(1) Customized codes include only aesthetic customization having no impact on Safety and EMC requirements

(2) cNus mark for North America cannot be coupled with the following variant codes:

Digit 1-2: 5T

Digit 3: 0

Digit 5: 2-3

(3) Ceiling Mounting Versions with cNus Mark are considered Fixed Applications and must be connected to Earth Protection. These devices are Class I Insulation according to IEC 60601-1.

(4) Aesthetic branding customization not impacting on Safety and Performance requirements

3.1 DESCRIPTION OF COMMON USER'S INTERFACE

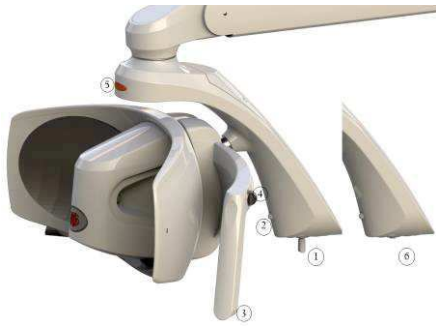

- | | | | |
|---|----------------------------------|---|----------------------------------|
| 1 | Joystick | 4 | Knob of the handle |
| 2 | Button for pairing and Tk change | 5 | Indicator Strip |
| 3 | Sterilizable Handle | 6 | Sensor (alternative to Joystick) |
| | | 7 | Button for Theia Tech |

4 INSTRUCTION FOR USE

The device must be cleaned before use (see Device Cleaning paragraph).

	Caution Do not use the device in flammable or explosive environments Simultaneous use of the light with electro-surgical devices can cause malfunctioning (flickering, no command, etc)
	Warning The Joystick must be handled with care to avoid breakages. Never move the light using the switch to grip.
	Note At the switching on the device makes a self diagnosis, and the Indicator strip starts blinking with different colours: blue, green and red. The following parameters are memorized by the lamp and made available at every switching on: <ul style="list-style-type: none"> • Last light intensity setting • light colour temperature Setting (for Tunable White variant)
	Warning Do not use the device if parts or enclosures are damaged or plays or gaps appear between: <ul style="list-style-type: none"> • Head Bow / Head Joint • Fixed Arm Joint / Swivel Arm Joint
	Warning The joystick must be handled with care to avoid breakages. Never move the light using the joystick.

4.1 SWITCHING ON/ OFF

Joystick

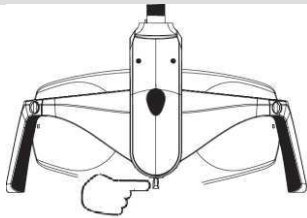

Push right or left and release
Acoustic signal: 1 beep

Sensor

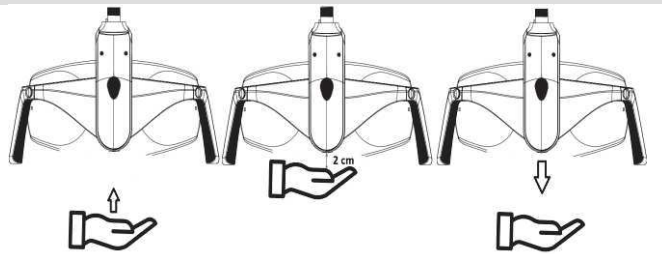

Bring the hand towards the sensor up to 2 cm and move the hand down
Acoustic signal: 1 beep

4.2 ADJUSTING THE LIGHT INSTENSITY

Joystick Increase Light Intensity

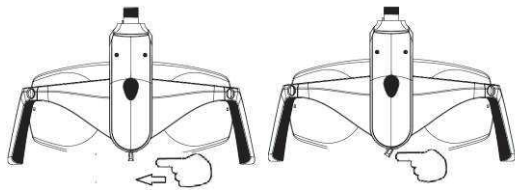

Push left and keep pushed until desired intensity is reached. Then release
Acoustic signal: 1 beep at command
Maximum intensity reached: continuous beep

Joystick Decrease light intensity



Push right and keep pushed until desired intensity is reached, then release.
Acoustic signal: 1 beep at command
Minimum intensity reached: continuous beep

Sensor - Increase and decrease light intensity

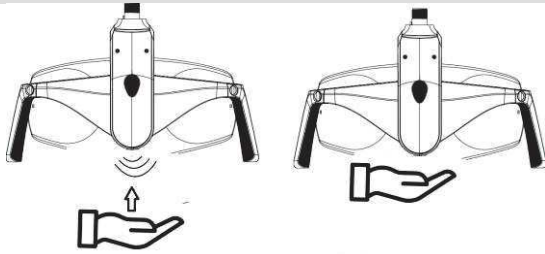

Bring the hand towards the sensor up to 2 cm and keep this distance until the desired light intensity is reached
 Acoustic signal: 1 beep at command
 Maximum intensity reached: 2 beeps
 Minimum intensity reached: 1 beep

i in sensor version the light intensity changes continuously decreasing until minimum and increasing until maximum

i Note when changing the light intensity the indicator light changes according to the illuminance level, according to the images below:



4.3 CHANGING COLOR TEMPERATURE ON TUNABLE WHITE VERSION

Joystick and Sensor

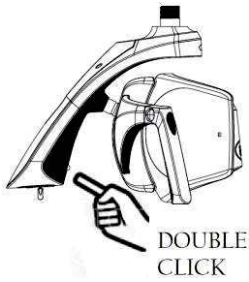





Every time a double click is performed, the Tk of the light changes.
 Repeat the procedure until the desired colour temperature is shown on the indicator light.
 2 beeps will inform the user that Tk is changing.

Sunlight Version	Tunable White Version		
TK 5000 K Green Luminous Indicator Strip	TK 4000 K Yellow Luminous Indicator Strip	TK 5000 K White Luminous Indicator Strip	TK 5700 K Blue Luminous Indicator Strip

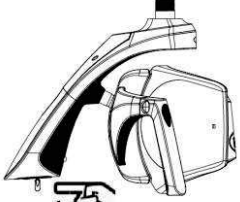
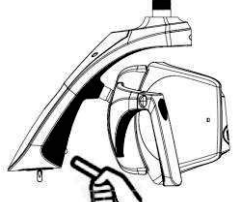
4.4 COMPOSAVE SETTING ON TUNABLE WHITE VERSION

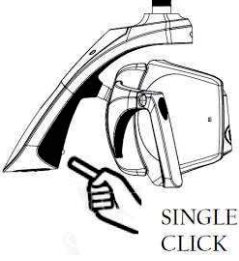
Composave setting allow the user to work with restorative material avoiding their polymerization. Select the composave setting as described below:

Joystick version option 1	Joystick version option 2	Visual information
 <p>Press and release</p>	 <p>SINGLE CLICK</p>	
Sensor version		Visual information
 <p>SINGLE CLICK</p>		





At the command selection of compo save a wigwag beep will be heard. Indicator strip changes in orange.



exit from the compo-save setting with a single click from Compo-save Setting

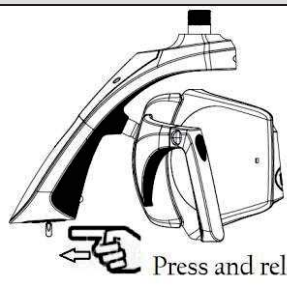
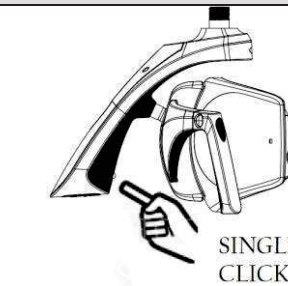

4.5 MINIMUM INTENSITY SETTING ON SOLAR VERSION

Joystick version	Sensor version	Visual Information
 <p>Press and release</p>	 <p>SINGLE CLICK</p>	

4.6 AUTO-ON SETTING

When the on-mode is set in on position the lamps turn on automatically (without a specific command from the user) when there is power supply.

4.7 SWITCHING ON/ OFF THEIA

	<p>The light on the fixed arm (secondary light) can be switched on/off and adjusted in synchro-mode with the operatorly light and its command. The secondary light can be manually operated using the button (7) on the fixed arm.</p> <p>If the secondary light is switched on after the operatorly light, it will be automatically synchronized.</p> <p>If the secondary light is switched on with the operatorly light switched off, it will be automatically settled at the maximum intensity.</p> <p> The light on the fixed arm is adjusted in synchro mode with head, it cannot be adjusted independently.</p>
--	--

4.8 REMOTE CONTROL

Make reference to the Dental Unit's instruction for use the Dental Light from the Dental Unit's control panel

4.9 SYNCRO MODE WITH FARO ROOM LIGHT

When present, the device can be connected by Radio Frequency (RF) connection to the Faro Room Light to create a synchronized lighting system.

The procedure to create this connection is called "pairing".

If more than one Room Lights are installed in the cabinet, take care that the other Room Lights are turned off or are turned on for more than 60 seconds.

To activate the "Pairing", proceed as follows:

1. Switch on the Faro Room Light. The Room Light will start Searching an input from the dental light for 60 seconds.

2. Within the 60 seconds, press the "Pairing" button on the dental lamp between 4 and 6 seconds. But not for more than 6 seconds (otherwise the procedure will be cancelled).

The Room Light activates the blue LED on the aluminium body.



If the blue LED does not switches on, it is possible another attempt (within the 60 seconds by the firsts). If 60 seconds past from the switching on of the Room Light, it is necessary to repeat the procedure from point 1.

3. After the blue LED switches on the room light, there are 60 seconds to confirm the "Pairing" by pressing the programming button placed on the remote control of the Room Light. At this point, the blue LED of the Room Light blinks at double frequency and then switches off. If the button on the remote controls is not pressed within 60 seconds, the blue LED switch off and the procedure must be repeated from point 1.

After the "Pairing", synchronization between the 2 lamps (dental light and room light) is enabled.

To DE-ACTIVATE THE SYNCHRONIZATION FUNCTION, proceed as follows:

Press the Synchro button from 2 to 4 second, then release it.

On release, a sound signal (Beep) will be heard and the blue LED on the Room Light lamp will go out to indicate that synchronization has been disabled.

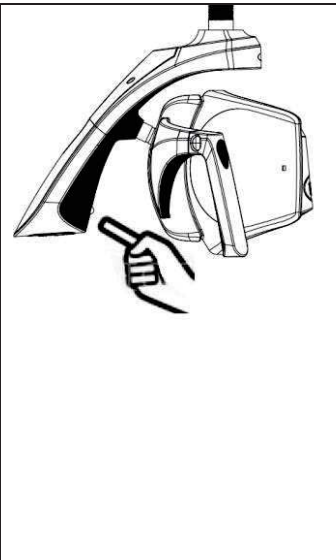

When the Faro Room Light is synchronized with the Dental Light the blue LED on the room light is lighted in steady mode. If the LED is off, the synchronization is not active.

The remote control is always enabled, so it is possible to change the illumination value in manual mode.

If the Dental Light is turned off, the room light will remain switched.

5 PREVENTIVE MAINTENANCE AND ROUTINE CHECKS



Only Service Engineer are allowed to perform corrective Maintenance and replacement of any part of the device, according to Manufacturer's Service Manual.

Checks	Frequency	Procedure	Responsible
No plays or space gaps between the junction points (points 1, 2, 3, 4)	Yearly		Service Engineer
Screws of connection points must be tightened and integer: <ul style="list-style-type: none"> screws 5 Screw 6. 	Yearly		Service Engineer
The nuts of connection points under carter 1, 2 must be well secured and safety screws intact. The screws under carter 3 must be well secured.	Yearly		Service Engineer
Check the absence of any oxidation into joints, arms or plastic parts.	Yearly	Visual inspection	Service Engineer
Check the main plate can be read	Yearly	//	Service Engineer
Check of damages on enclosure and plastic joints integrity.	Yearly		Service Engineer
Electrical Safety according EN 62353 1. Dielectric strength 2. Current Leakage	Every two years	Use the parameters defined into IEC 60601-1	Service Engineer
Light checks	Every two years	With a spectroradiometer check the values for: Max Luminance: >35000 lux CRI > 85 Radial power on blue light: <100 W/m ²	Service Engineer

6 CLEANING AND DISINFECTION

	<p>Warning against danger of wear and corrosion and falling suspended mass</p> <p>For all metal or plastic parts it is strictly forbidden to use substances that are</p> <ul style="list-style-type: none"> - abrasive, - corrosive, - acids, - substances containing chlorine or chloride ions, phosphorous or phosphorous ions, - detergents with Trilene base, petrol, white spirit, chlorine or similar. <p>Do not use detergents-disinfectants containing the following substances to clean plastic parts:</p> <ul style="list-style-type: none"> - Ammonium Hydroxide - Sodium Hydroxide - Hydrogen peroxide - Ammonium Chloride - Methylene chloride - Methyl alcohol - Acids and corrosive substances of all kinds. <p>It is forbidden to directly spray any chemical substance on the device. It is forbidden the use of wet wipes without rinsing.</p>
	<p>Faro tested and suggests the use of the following disinfectants, for plastic parts and metal parts:</p> <ul style="list-style-type: none"> - Durr FD366 Sensitive - Faro Perflex Advanced - Water-alcohol based disinfectants with 70% isopropyl alcohol or ethanol are suitable.

6.1 CLEANING OF THE REFLECTING PARABOLAS

Cleaning must be carried out using a soft cloth in cotton or absorbent cotton with ethyl alcohol.
Water-alcohol based disinfectants are suitable with 70% isopropyl alcohol or ethanol.

	<p>Caution - potential damage or wear on the parabolas</p> <p>Never spray detergent directly on the parabolas.</p> <p>Cleaning operations on the parabolas must be carried out wearing gloves, to avoid leaving fingerprints on the surfaces.</p> <p>Never use detergents containing surfactants or water-repellents that depositing can leave streaks. Slight streaking will not prejudice the quality of the light.</p> <p>Products differing from those suggested could damage the parabolas.</p> <p>If in doubt, contact FARO customer care.</p>
--	---

6.2 CLEANING AND DISINFECTION OF THE HEAD

Cleaning must be carried out using a soft cloth in cotton wetted with disinfectant solution.
Always squeeze the cloth to remove all the liquid in excess.

6.3 CLEANING AND DISINFECTION OF ARMS

Always use a cloth soaked in disinfectant approved to disinfect the surfaces and pass it over.
Always squeeze the cloth to remove all the liquid in excess.

7 STERILIZATION OF THE HANDLES

	<p>Warning - danger of cross contamination</p> <p>The handles are not supplied sterile, they must therefore be sterilised before use. The handles must be sterilised before each patient.</p>
---	--

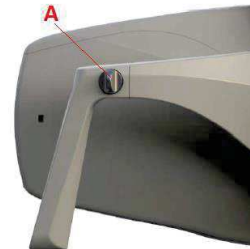

7.1 REMOVAL OF THE HANDLES

To remove the handle, unscrew knob "A" and remove it from the support.

7.2 DECONTAMINATION AND DISINFECTION

Before sterilising the handles, they must be decontaminated and disinfected.
To disinfect, Faro has tested the following products for disinfection:

- Faro Perflex Advance
- Durr FD366 Sensitive

	<p>WARNING - danger of plastic breaking</p> <p>The handles cannot be disinfected by thermo-disinfection.</p>
--	---

7.3 STERILIZATION

The handles must be packaged in compliance with EN 868-5.

The handles can be sterilised with standard cycles 121°/134° C up to two hundred (200) cycles or however up to loss of the mechanical performance.

The parameters of the sterilisation cycle are as follows:

Cycle EN 13060	Temperature	Pressure	Holding Time Minimum
B	121°C	207 kPa	15 min
B	134°C	308 kPa	3 min

8 TROUBLESHOOTING

8.1 ERROR LIST

Error	Description	Indicator Strip	Acoustic indication
E1	Open Led channel 1	First sector blinking. Colour set-up: RED	3 short beeps repeated 3 times
E2	OPL Open Led channel 2	First and second sectors blinking Colour set-up: RED	
E3	High temperature on the Led group	No	No
E4	Low or High input voltage	All sectors blinking together. Colour set-up: RED	5 lounge beeps
E5	Over Temperature Protection active	First sector blinking. Colour set-up: PURPLE	3 lounge beeps
E6	High temperature on the board	All sectors blinking sequentially. Colour set-up: PURPLE	3 lounge beeps

9 TECHNICAL SPECIFICATIONS

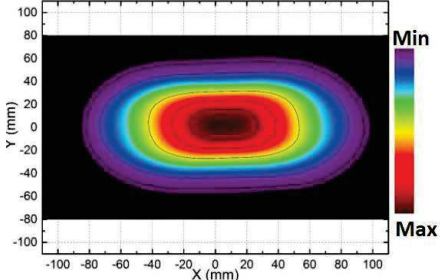
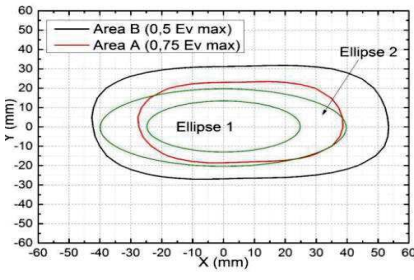
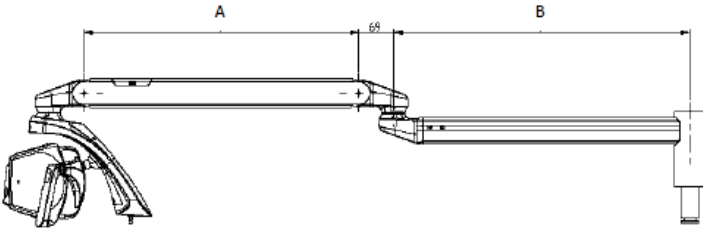
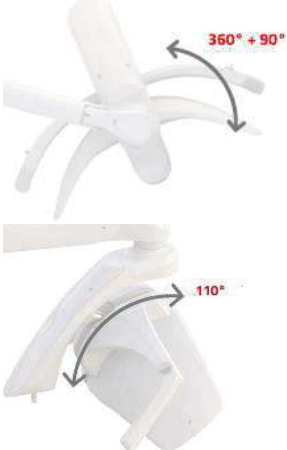
	Dental Light Dental Light Head	Dental Light with Theia Tech
Power Supply	24 V ac $\pm 10\%$ 50/ 60Hz; 32 V dc $\pm 10\%$;	24V ac $\pm 10\%$ -50/60 Hz; 32 V dc $\pm 10\%$;
Max Power :	24 V ac 26 VA 32 V dc 14 VA	24 V ac: 40 VA 32 V dc: 28 VA
Recommended fuses for installation (not supplied in charge to installation)	24 V ac T1.6AL 250V 32 V dc T1.25AL 250V	24 V ac: T2AL 250V 32 V dc: T1.25AL250V
Protection against electrical hazard	Class II Class I for Ceiling Mounting for Canada US Certification NB: final classification of the Protection Class of the Medical System is demanded to the Service Engineer in charge of installation or to the manufacturer	
Classification against IEC 62471	Class I - Labelling Exempt	
Max illuminance (*)	> 45.000 lux	
Color Rendering Index (*)	> 95	
Correlated Colour Temperature CCT (*)	Sunlight Version: 5.000 K Tunable White Versions: 4000 K – 5000 K – 5700 K Composave setting : 2700 K	
Spot Dimension (*)	180 mm x 110 mm	
Max Hard Shadow ISO 9680 (*)	10 mm x 5 mm	
Nature of the radiation	Non ionizing Radiation	
Type of radiation	Visible lights	
Typical illuminance Pattern ISO 9680		
Typical illuminance Pattern ISO 9680		
Overall Movements		
Head Rotations		

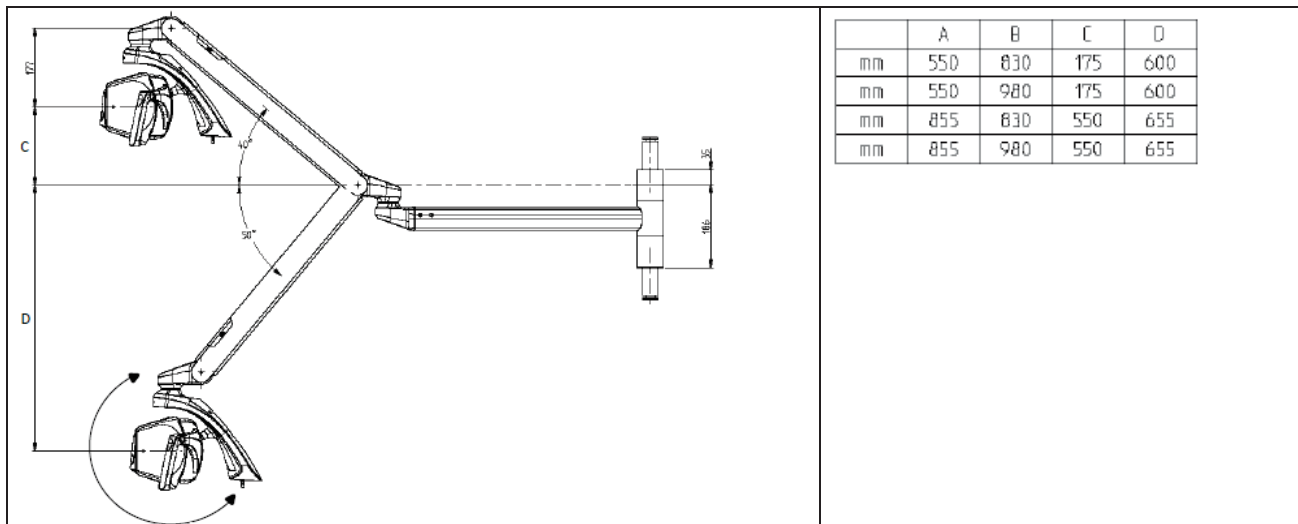

(*) Typical optical values subjected to tolerances

Measurement performed at 700 mm distance. Contact Faro for the correct procedure for the measurement.

9.1 STORAGE AND TRANSPORTATION: ENVIRONMENTAL CONDITIONS

The device in the original packaging can be transported and stored for a maximum period of 15 weeks if the following environmental conditions are met:

- Environmental temperature from -20°C to +70°C
- Relative humidity from 10% to 90%
- Atmospheric pressure from 50 kPa to 106 kPa

9.2 USE: ENVIRONMENTAL CONDITIONS

- The device must be used in the following environmental conditions:
- Temperature from 10° to 40°C
- Max altitude: 2000 m
- Relative humidity from 30% to 75%



DAL 1948: ESPERIENZA
E RINNOVAMENTO

 **FARO S.p.A.**

via Faro, 15 - 20876 Ornago (MB) - Italy

Tel. +39 039.68781 - Fax +39 039.6010540

www.faro.it - comm.italia@faro.it - export@faro.it

EVA

Dental Operating Light

Medical Device

Class I



FARO SpA si riserva il diritto di modificare, senza preavviso, le caratteristiche indicate nel presente manuale.
FARO SpA reserves the right to change the specifications of this equipment without notice.
FARO SpA se réserve le droit de modifier, sans préavis, les caractéristiques dans ce manuel.
FARO SpA behält sich recht vor, jederzeit stillschweigend technische oder bauliche Änderung vorzunehmen.
FARO SpA se reserva el derecho de modificar sin aviso previo la características incluidas en el presente manual de uso.